



Equipped with AEM® Dryflow™ Filter
No Oil Required!

INSTALLATION INSTRUCTIONS

PART NUMBER: 21-424

| | | | | |
|-----------|----------------|---------|----------|-----------------------|
| 2003 | DODGE Neon R/T | L4-2.0L | | C.A.R.B. E.O. # D-670 |
| 2001-2002 | DODGE Neon | L4-2.0L | ACR, R/T | C.A.R.B. E.O. # D-670 |

* **NOTE:** Legal in California only for racing vehicles which may never be used upon a highway

PARTS LIST

| Description | Qty. | Part Number |
|--------------------------------------|------|-------------|
| Element Parts Kit 2.50 X 5" Dry Ele. | 1 | 21-201DK |
| Upper Pipe | 1 | 2-516 |
| Lower Pipe | 1 | 2-517 |
| Hose, Silicone 2.50x3" Blk. | 2 | 5-250 |
| Hose, Silicone 2.50x2" Black | 1 | 5-252 |
| Hose; 3/8"ID X 22"L | 1 | 5-1022 |
| Mount, Rubber 1" X 6mm | 1 | 1228599 |
| Grommet, 1/2" | 1 | 784634 |
| Washer, 6mm Soft Mount | 1 | 559999 |
| Nut, M6 Hex Serrated | 1 | 444.460.04 |
| 1/2' Bnd. Hose Clamp, 2.15-3.00" | 6 | 9440 |
| Hose Clamp, 3/4" | 2 | 4093-5 |
| 1/2" Bnd. Hose Clamp, 2.31-3.25" | 1 | 9444 |

Read and understand these instructions **BEFORE** attempting to install this product. Failure to follow installation instructions and not using the provided hardware may damage the intake tube, throttle body and engine.

The AEM® intake system is a performance product that can be used safely during mild weather conditions. During harsh and inclement weather conditions, you must return your vehicle to stock OEM air box and intake tract configuration. Failure to follow these instructions will void your warranty.

1. Preparing Vehicle

- a. Make sure vehicle is parked on level surface.
- b. Set parking brake.
- c. If engine has run in the past two hours, let it cool down.
- d. Disconnect negative battery terminal.
- e. Do not discard stock components after removal of the factory system.

2. Removal of stock system

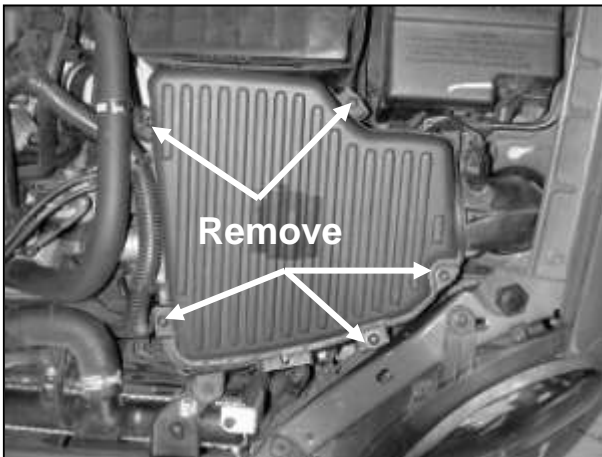

a. Loosen the five screws securing the stock air box lid. Remove the air box lid from the vehicle.



b. Remove the Inlet Air Temperature (IAT) sensor. The metal band will need to be pried off with a flat-head screwdriver. Use care to avoid damaging the IAT sensor.

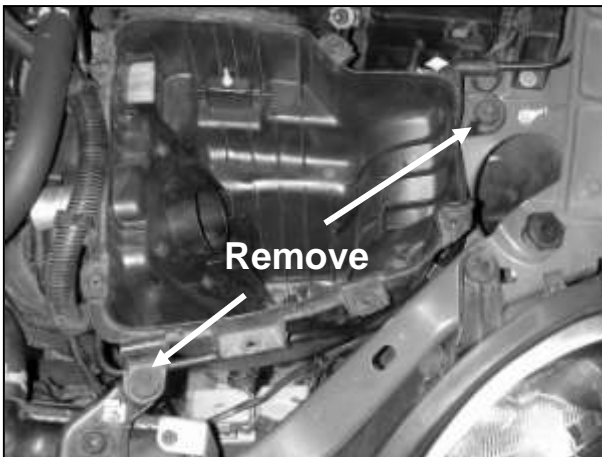

c. Remove the air filter element and the two lower air box mounting bolts.

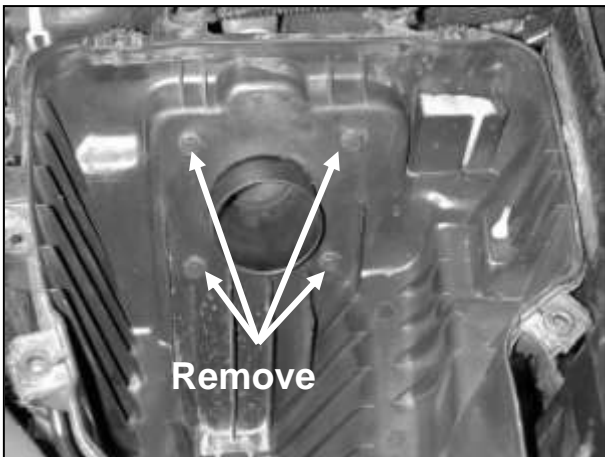

d. Remove the four screws that hold the throttle body to the lower air box.



e. Remove the breather hose from the lower air box. Remove the lower air box from the vehicle.

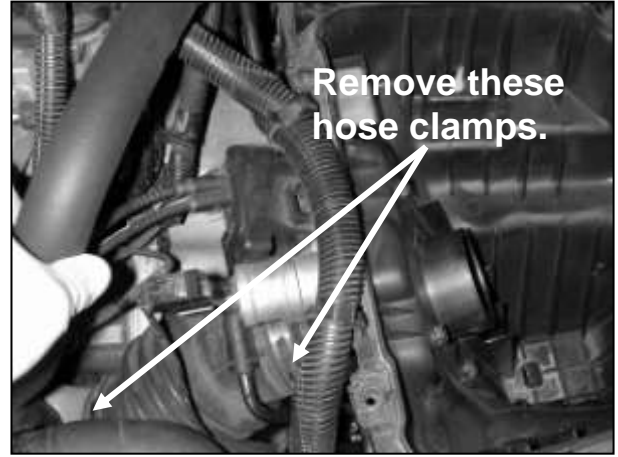

f. Loosen the two hose clamps on the rubber intake tube between the throttle body and intake manifold. Remove the rubber tube from the vehicle.

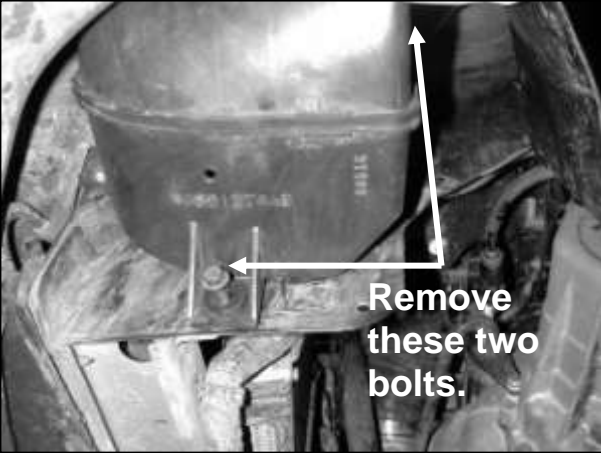

g. Raise the front of the vehicle with a jack. Refer to your owner's manual for proper jack and jack stand placement to properly support vehicle. Support your vehicle using properly rated jack stands before wheel removal or while working under the vehicle.
NEVER WORK UNDER A VEHICLE WITHOUT USING JACK STANDS.
Remove the driver side wheel. Pull back the driver's side fender lining to gain access to the resonator box. Remove the lower resonator box mounting bolts and remove the resonator box from the vehicle.

3. Installation of AEM® intake system.

a. When installing the intake system, do not completely tighten the hose clamps or mounting hardware until instructed to do so.



b. Install the 2.50" x 2.00" silicone hose on the shorter leg of the short AEM® intake pipe. Install one of the 2.50" x 3.00" silicone hoses on the longer leg of the same pipe. Loosely secure the hoses with the four 2.50" hose clamps.



c. Install the short AEM® intake pipe between the intake manifold and the throttle body. The longer leg attaches to the intake manifold and the shorter leg attaches to the throttle body. Snug the hose clamps to hold the pipe in place, but do not tighten, as further adjustment will be needed.

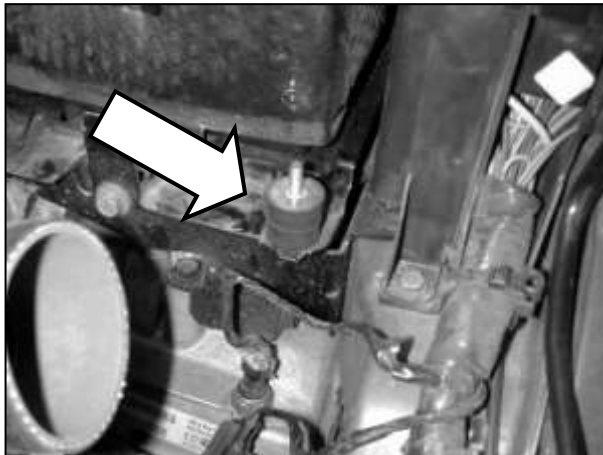

d. Remove the bolt from the right side of the battery tray and replace it with the supplied rubber mount.



e. Install the remaining supplied 2.50" x 3.00" silicone hose on the throttle body and loosely secure with the remaining 2.50" hose clamps.



f. Install the supplied rubber grommet into the back of the long AEM® intake pipe. This is where the IAT sensor will be installed.



g. Install the long AEM® intake pipe into the vehicle. Insert the end nearest the bracket into the silicone hose on the throttle body and loosely secure with the hose clamp. The bracket should line up with the rubber mount installed in step 3d. Install the supplied washer and lock nut on to the rubber mount. Refer to the following diagram for proper rubber mount installation.

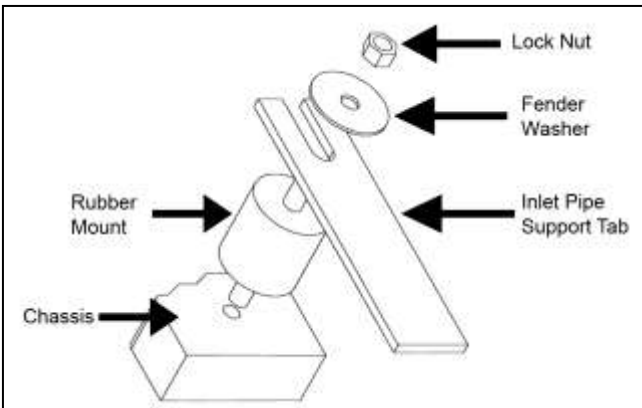

h. Proper installation of the rubber mount assembly.



i. Install the AEM® air filter from under the vehicle and tighten the hose clamp. Install the IAT sensor into the grommet installed in step 3f.



j. Remove the rubber elbow from the breather hose removed in step 2e. Replace it with the supplied length of breather hose and hose clamp.



k. Connect the other end of the breather hose to the nipple on the AEM® intake pipe with the remaining supplied hose clamp. Route the hose carefully to avoid kinking it.

4. Reassemble Vehicle

- a. **Fender liner:** Install the fender liner and any hardware that was removed in steps 2g.
NOTE: Failure to install the fender liner will result in diminished performance and increase the potential for engine damage due to water ingestion in rainy conditions.
- b. **Wheel:** Install the driver's side wheel using the factory torque specification (see owner's manual).
- c. Position the inlet pipes for the best fitment. Be sure that the pipes or any other components do not contact any part of the vehicle. Tighten the rubber mount, all bolts, and hose clamps.
- d. Check for proper hood clearance. Re-adjust pipes if necessary and re-tighten them.
- e. Inspect the engine bay for any loose tools and check that all fasteners that were moved or removed are properly tightened.
- f. Reconnect negative battery terminals and start engine. Let the vehicle idle for 3 minutes. Perform a final inspection before driving the vehicle.

5. CARB Sticker Placement

- a. The C.A.R.B. exemption sticker, (attached), must be visible under the hood so that an emissions inspector can see it when the vehicle is required to be tested for emissions. California requires testing every two years, other states may vary.

6. Service and Maintenance

- a. It is recommended that you service your AEM® Dryflow™ filter every 20,000 miles for optimum performance. Use AEM Dryflow cleaning kit part # 21-110.
- b. Use aluminum polish to clean your polished AEM® intake tube.
- c. Use window cleaner to clean your powder coated AEM® intake tube. **(NOTE: DO NOT USE aluminum polish on powder coated AEM intake tubes).**



Factory air box system installed



AEM® intake system installed

If AEM® Bypass Valve (part # 20-401S) is installed, install the bypass valve as shown in the figure below. The intake pipe will require modification so follow the instructions included with the AEM Bypass Valve accordingly.

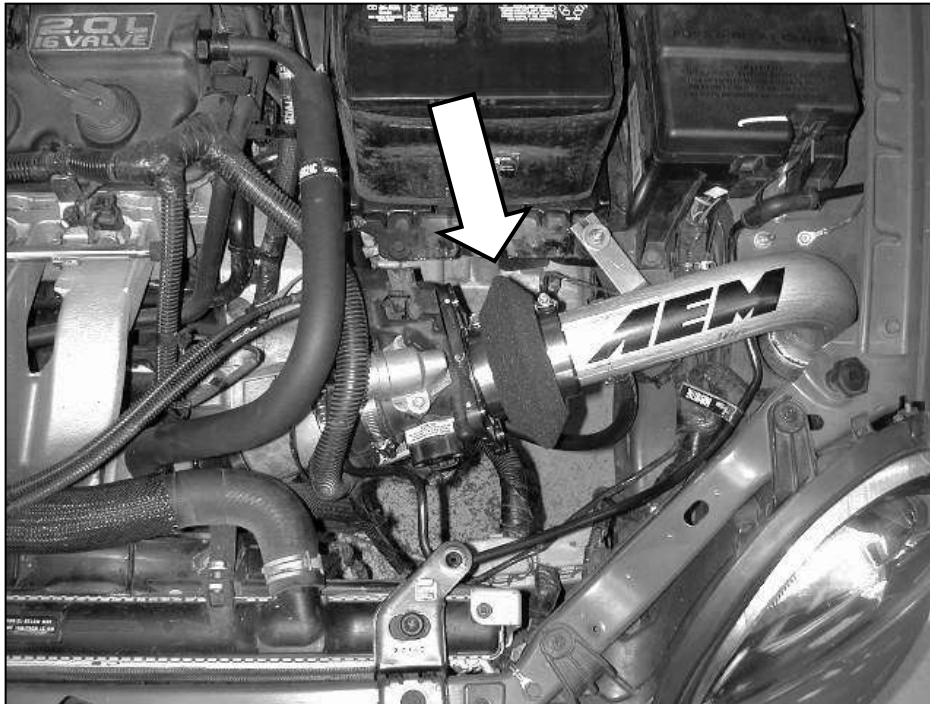

For technical inquiries
e-mail us at
sales@aemintakes.com
or
call us at
800.992.3000

AEM Air Intake System Warranty Policy

AEM® warrants that its intake systems will last for the life of your vehicle. AEM will not honor this warranty due to mechanical damage (i.e. improper installation or fitment), damage from misuse, accidents or flying debris. AEM will not warrant its powder coating if the finish has been cleaned with a hydrocarbon-based solvent. The powder coating should only be cleaned with a mild soap and water solution. Proof of purchase of both the vehicle and AEM intake system is required for redemption of a warranty claim.

This warranty is limited to the repair or replacement of the AEM part. In no event shall this warranty exceed the original purchase price of the AEM part nor shall AEM be responsible for special, incidental or consequential damages or cost incurred due to the failure of this product. Warranty claims to AEM must be transportation prepaid and accompanied with dated proof of purchase. This warranty applies only to the original purchaser of product and is nontransferable. Improper use or installation, use for racing, accident, abuse, unauthorized repairs or alterations voids this warranty. AEM disclaims any liability for consequential damages due to breach of any written or implied warranty on all products manufactured by AEM. Warranty returns will only be accepted by AEM when accompanied by a valid Return Merchandise Authorization (RMA) number. Credit for defective products will be issued pending inspection. Product must be received by AEM within 30 days of the date RMA is issued.

If you have a warranty issue, please call (800) 992-3000 and our customer service department will assist you. A proof of purchase is required for all AEM warranty claims.