



TYPHOON INTAKE SYSTEMS

INSTALLATION INSTRUCTIONS

69-6027
MAZDA
2007-08 6
L4-2.3L

TOOLS NEEDED:

3mm allen wrench
10mm socket
12mm socket
extension
flat blade screwdriver
phillips screwdriver
pliers
ratchet

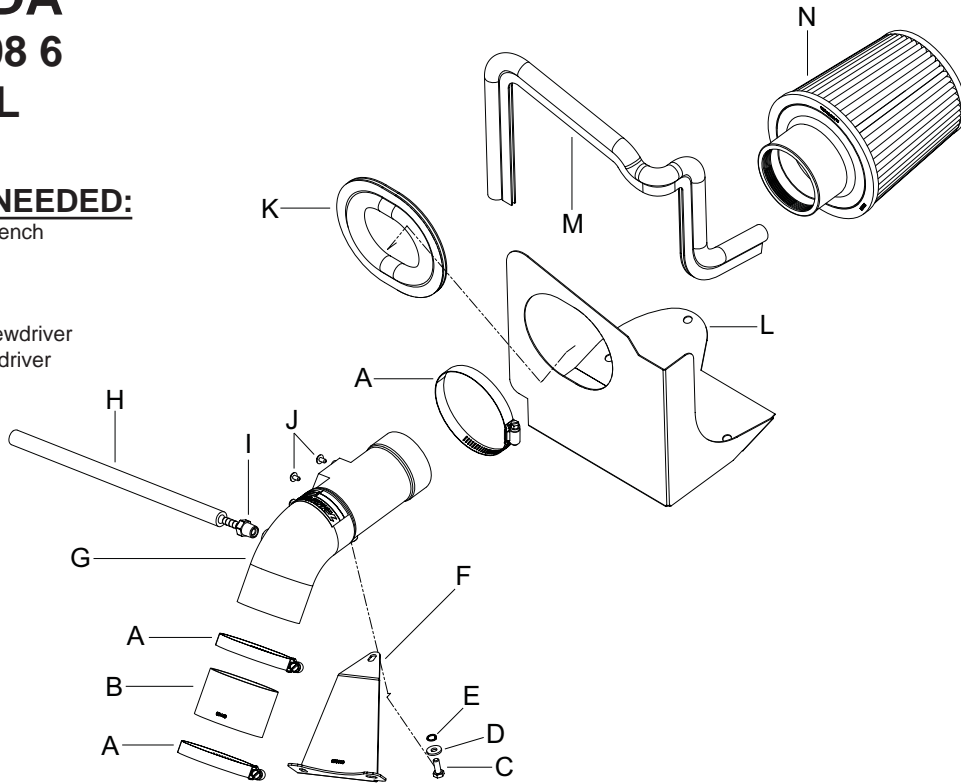

PARTS LIST:

	Description	Qty.	Part #
A	Hose Clamp #44	3	08577
B	Hose; Typhoon 2-3/4" x 2"L, Blk.	1	08440
C	Bolt; 6MM-1.00 x 16MM, SS	1	07812
D	Washer; 1/4"ID x 5/8"OD - SAE	1	08275
E	Washer; 1/4" Lock, ZN	1	08198
F	Bracket	1	070100
G	Intake Tube	1	27556TTK
H	Hose; 3/8"ID x 12"L, Black Silicone	1	08412
I	Vent; Strt., 3/8"Hose, 1/4"NPT, Plas.	1	08047
J	Bolt; M4 x .7 x 8MM, Buttonhead, SS	2	07741
K	Edge Trim (17")	1	102469
L	Heat Shield	1	074049
M	Edge Trim (35")	1	102471
N	Air Filter	1	RU-4870

NOTE: FAILURE TO FOLLOW INSTALLATION INSTRUCTIONS AND NOT USING THE PROVIDED HARDWARE MAY DAMAGE THE INTAKE TUBE, THROTTLE BODY AND ENGINE.

TO START:

1. Turn off the ignition and disconnect the negative battery cable.

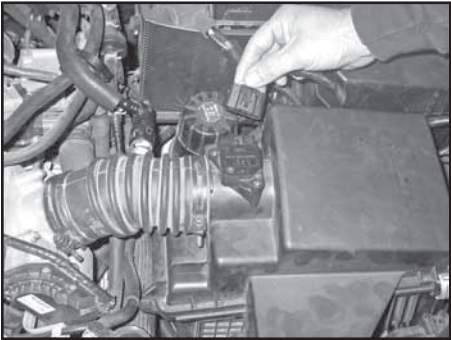

2. Disconnect the mass air sensor electrical connection.

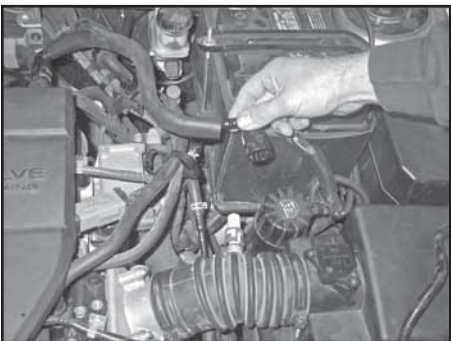

3. Disconnect the crank case vent hose from the intake tube as shown.

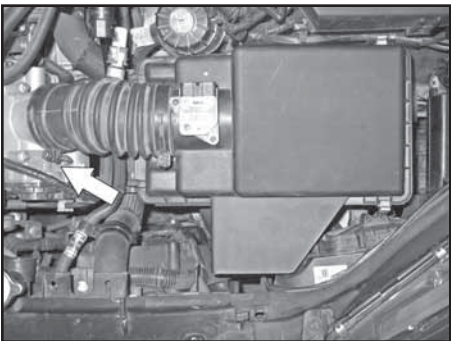

4. Loosen the hose clamp which secures the intake tube to the throttle body.

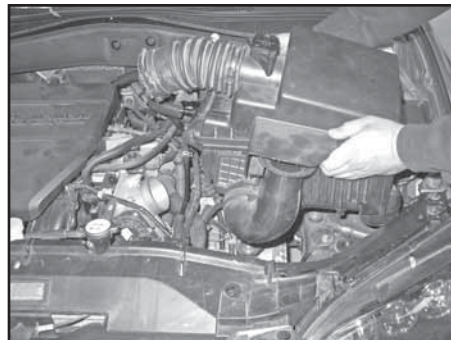

5. Pull up firmly on the air box assembly to dislodge it from the mounting grommets and then remove the air box assembly from the vehicle.

NOTE: K&N Engineering, Inc., recommends that customers do not discard factory air intake.

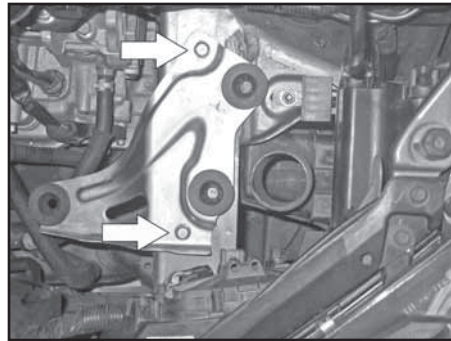

6. Remove the two bolts which secure the air box mounting bracket to the inner fender and then remove the bracket from the vehicle.

NOTE: These bolts will be reused in a later step.

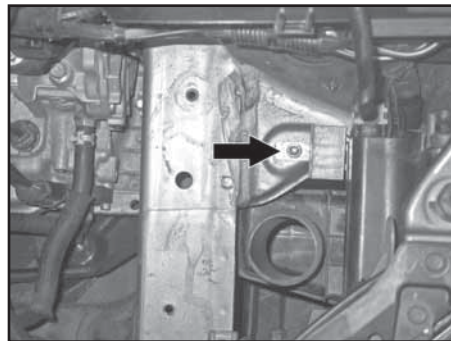

7. Remove the bolt which retains the ground strap to the inner fender.

NOTE: This bolt will be reused in a later step.

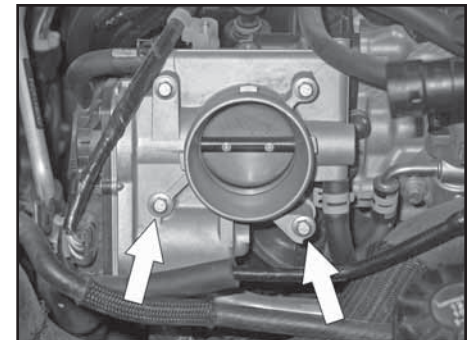

8. Remove the two lower throttle body mounting bolts shown.

NOTE: These bolts will be reused in the next step.

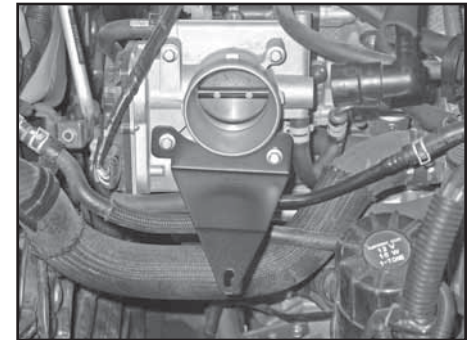

9. Install the intake tube mounting bracket onto the throttle body and secure with the original bolts removed in the previous step.



10. Install the provided long edge trim onto the heat shield as shown.

NOTE: Some trimming of the edge trim will be necessary.

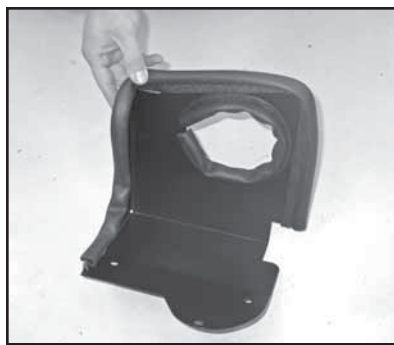

11. Install the provided short edge trim into the hole of the heat shield as shown.

NOTE: Some trimming of the edge trim will be necessary.

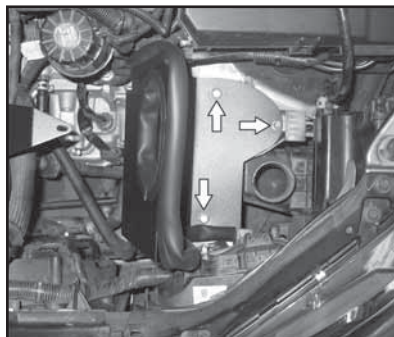

12. Install the heat shield assembly onto the inner fender and secure with the factory bolts removed during steps #6 and #7.

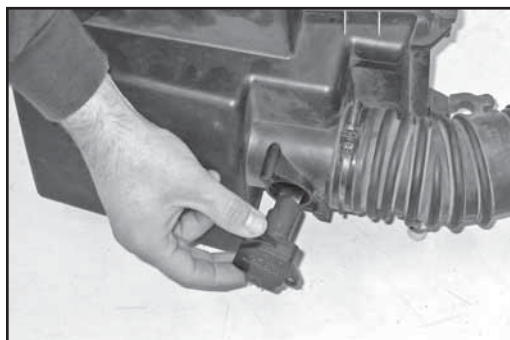

13. Remove the two bolts which secure the mass air sensor to the factory air box and then remove the mass air sensor as shown.



14. Install the mass air sensor into the K&N® intake tube and secure with the provided hardware.

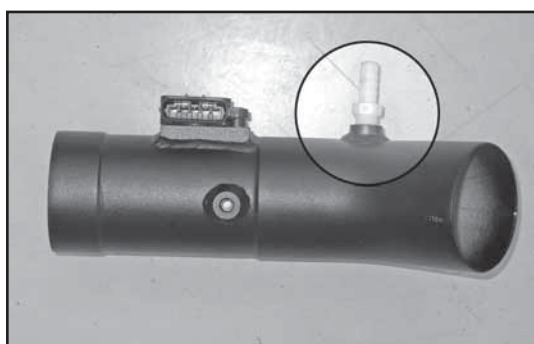

15. Install the provided vent fitting into the K&N® intake tube as shown.

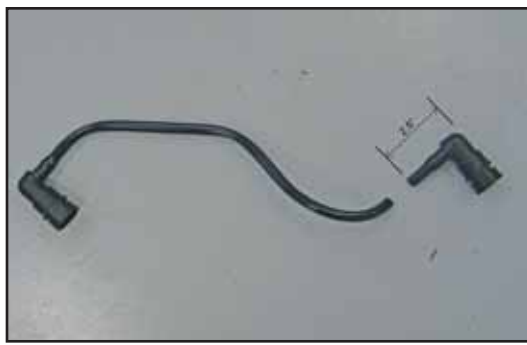

16. Remove the crank case vent fitting from the engine valve cover, and then cut off the intake tube end of the assembly 2.5" from the end as shown. Reinstall the crank case tube onto the valve cover.

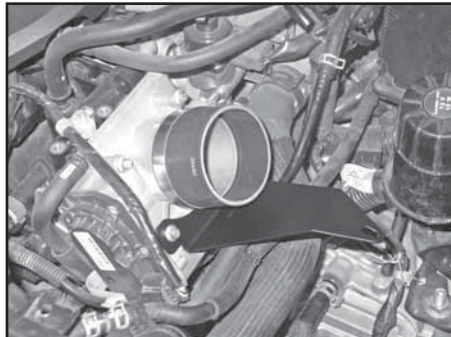

17. Install the silicone hose (08440) onto the throttle body and secure with the provided hose clamp.



18. Install the K&N® intake tube into the silicone hose at the throttle body and align with the tube mounting bracket. Secure the intake tube with the provided hose clamp and hardware.

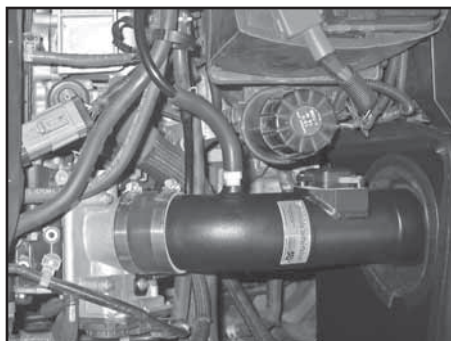

19. Install the provided crank case vent hose onto the factory vent tube and onto the vent fitting installed into the K&N® intake tube as shown.

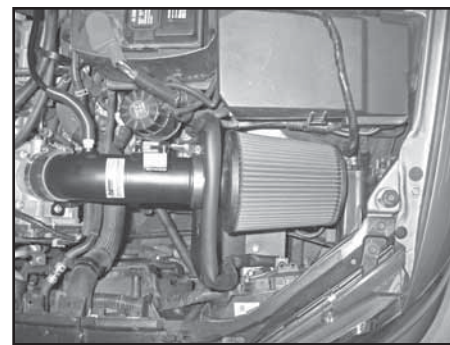

20. Install the K&N® air filter onto the K&N® intake tube and secure with the provided hose clamp.

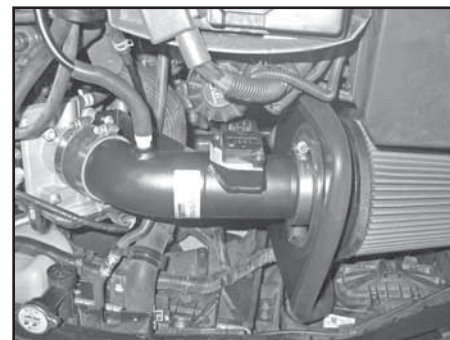

21. Reconnect the mass air sensor electrical connection.

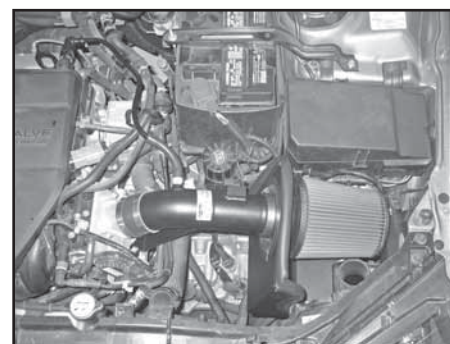

22. Reconnect the vehicle's negative battery cable. Double check to make sure everything is tight and properly positioned before starting the vehicle.

23. It will be necessary for all K&N® high flow intake systems to be checked periodically for realignment, clearance and tightening of all connections. Failure to follow the above instructions or proper maintenance may void warranty.

ROAD TESTING:

1. Start the engine with the transmission in neutral or park, and the parking brake engaged. Listen for air leaks or odd noises. For air leaks secure hoses and connections. For odd noises, find cause and repair before proceeding. This kit will function identically to the factory system except for being louder and much more responsive.

2. Test drive the vehicle. Listen for odd noises or rattles and fix as necessary.

3. If road test is fine, you can now enjoy the added power and performance from your kit.

4. K&N Engineering, Inc., suggests checking the air filter element periodically for excessive dirt build-up. When the element becomes covered in dirt (or once a year), service it according to the instructions on the Recharger® service kit, part number 99-5050 or 99-5000.