

# K&N TYPHOON INTAKE SYSTEMS



## INSTALLATION INSTRUCTIONS

**69-3523**  
**FORD**  
**2005-09 MUSTANG GT**  
**V8-4.6L**

NOTE: C.A.R.B. E.O.# D-269-32 APPLIES ONLY TO 2005-06 MODEL YEAR VEHICLES

### TOOLS NEEDED:

- Flat Blade Screwdriver
- Ratchet
- Extension
- 8mm Socket
- 10mm Socket
- 10mm Wrench
- 2.5mm Allen Wrench

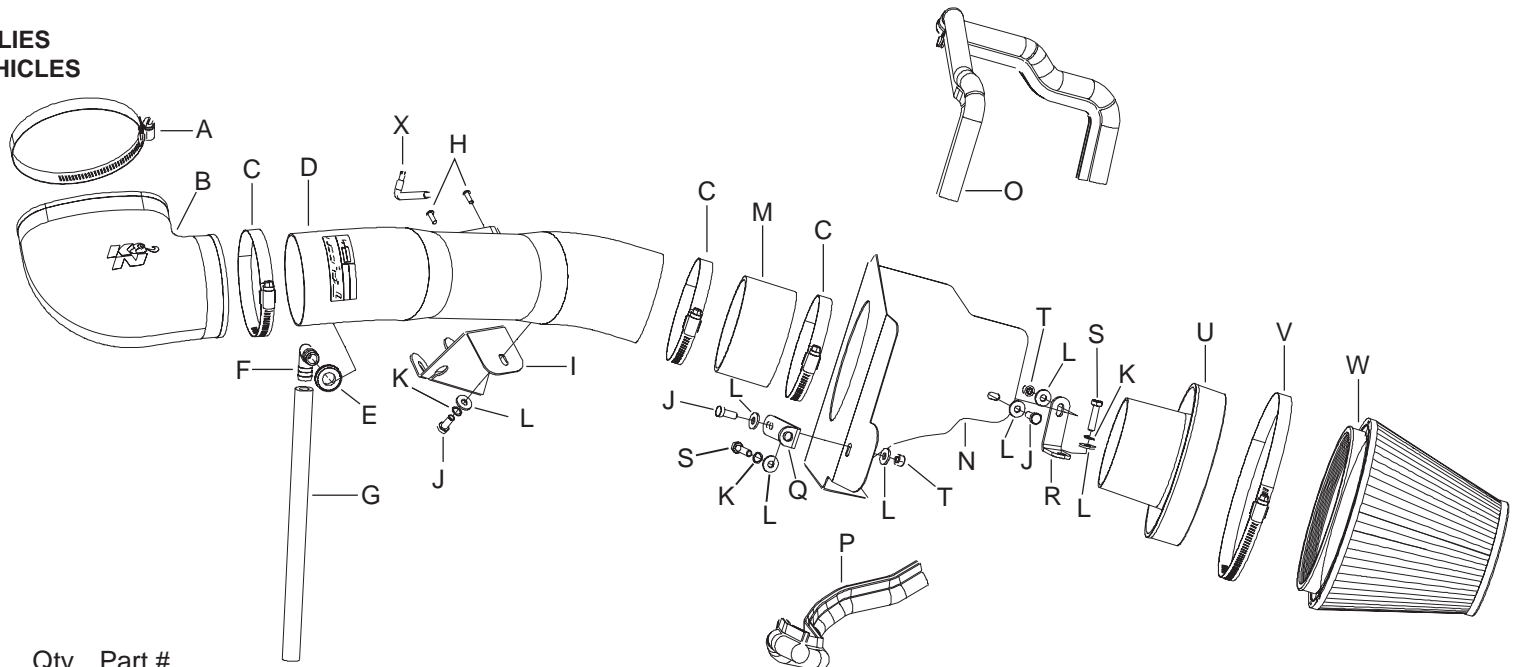

### PARTS LIST:

Description	Qty.	Part #	Description	Qty.	Part #	Description	Qty.	Part #
A Hose Clamp #72	1	08671	I Bracket	1	26639	Q Bracket "L"	1	07158
B Hose; Oval To 3.5" id, 90 Deg Elbow	1	084094	J Bolt; 6mm-1.00 X 16mm SS Hex	3	07812	R Bracket "L"	1	070812
C Hose Clamp #56	3	08620	K Washer; Wave 6mm	3	08277	S Bolt; 6mm-1.00 X 25mm Hex SS	2	07858
D Intake Tube	1	27504	L Washer; Flat SS 6mm	7	08269	T Nut; 6mm Nylock	2	07553
E Grommet	1	08167	M Hose; 3.5" id X 2" L, Silicone	1	08698	U Adapter #452	1	21518
F Hose Mender; 90 Deg	1	08065	N Heat Shield	1	074038	V Hose Clamp #104	1	08697
G Hose; 5/16" id X 21" l, Silicone	1	08409	O Edge Trim 30"	1	102489	W Air Filter	1	RF-1048
H Bolt; M4-.7 X 12mm, B/H/A	2	07726	P Edge Trim 23"	1	102495	X Wrench; Torx T20-T/R, L-Key	1	69801

**NOTE: FAILURE TO FOLLOW INSTALLATION INSTRUCTIONS AND NOT USING THE PROVIDED HARDWARE MAY DAMAGE THE INTAKE TUBE, THROTTLE BODY AND ENGINE.**

### TO START:

1. Turn off the ignition and disconnect the negative battery cable.

**NOTE: Disconnecting the negative battery cable erases pre-programmed electronic memories. Write down all memory settings before disconnecting the negative battery cable. Some radios will require an anti-theft code to be entered after the battery is reconnected. The anti-theft code is typically supplied with your owner's manual. In the event your vehicles' anti-theft code cannot be recovered, contact an authorized dealership to obtain your vehicles anti-theft code.**

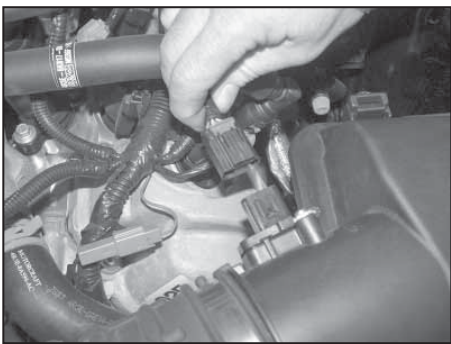

2. Release the red locking tab and then disconnect the mass air sensor electrical connection

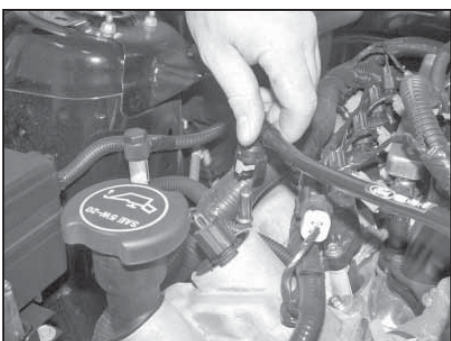

3. Rotate the green locking tab clockwise and then disconnect the crank case breather hose from the valve cover as shown.



4. Loosen the hose clamps, which secure the intake tube to the throttle body and air box, then remove the intake tube as shown.

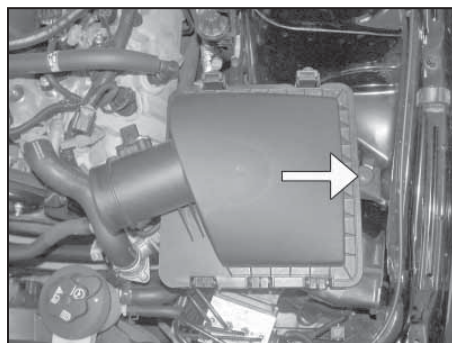

5. Remove the air box mounting bolt shown.

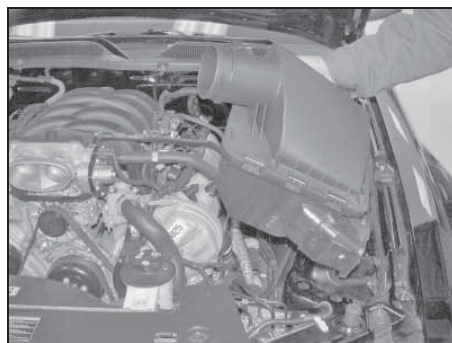

6. Remove the air box assembly as shown. **NOTE: K&N recommends customers do not discard their factory air intake.**

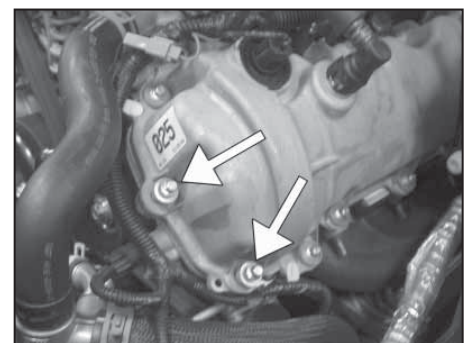

7. Remove the two valve cover bolts shown. **NOTE: These bolts will be reused.**

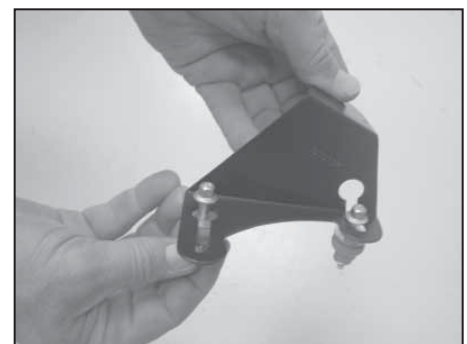

8. Install the valve cover bolts removed in step #7 into the tube mounting bracket as shown passing through the key hole portion and then slide the bolts to the end of the slots.



9. Install the tube-mounting bracket onto the valve cover as shown and secure with the stock hardware removed in step #7.

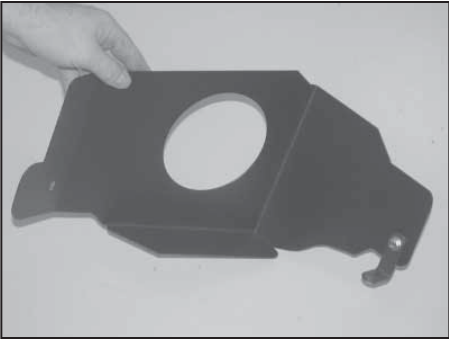

10. Install the "L" bracket (070812) onto the rear of the heat shield as shown with the provided hardware.

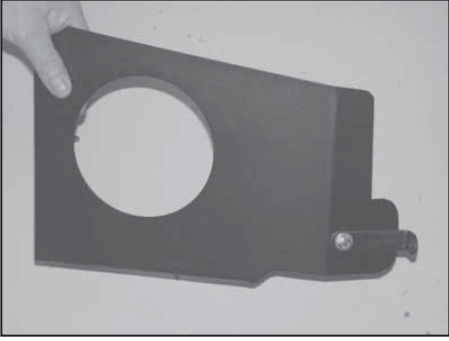

11. Install the "L" bracket (07158) onto the front of the heat shield as shown with the provided hardware.

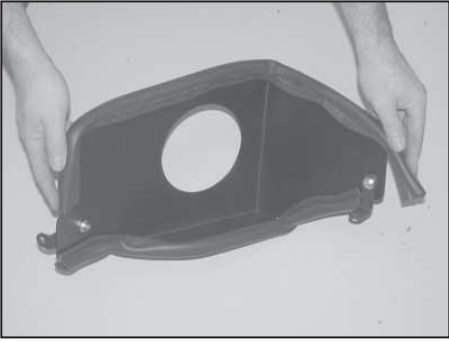

12. Install the edge trim onto the heat shield as shown.

**NOTE: Some trimming of the edge trim may be necessary for proper fit.**

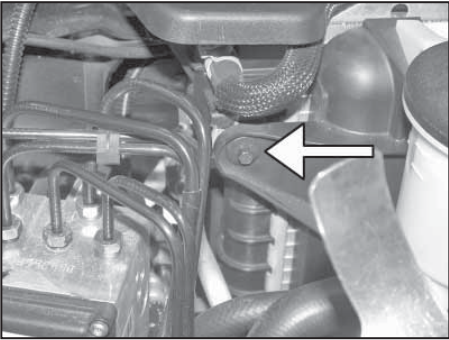

13. Remove the radiator fan shroud mounting bolt shown.

**NOTE: This bolt will not be reused.**

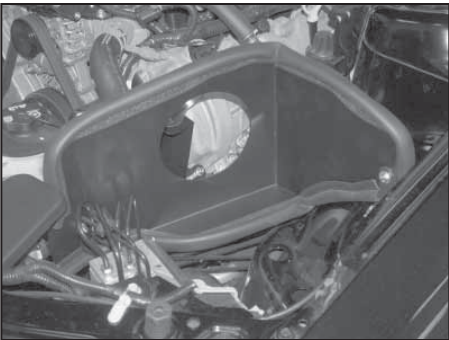

14. Install the heat shield and secure with the provided hardware as shown.

**NOTE: The forward mounting bracket will mount to the radiator fan shroud mounting location and the rear bracket will mount to the air box mounting location.**

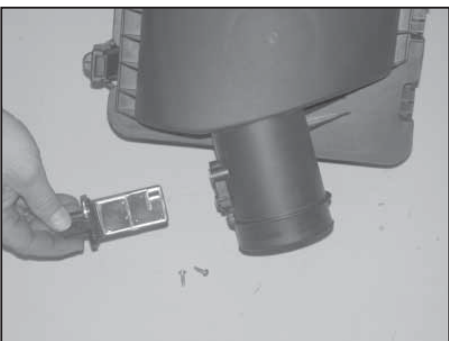

15. Remove the mass air sensor from the factory air box with the T20 "TORX" wrench provided.

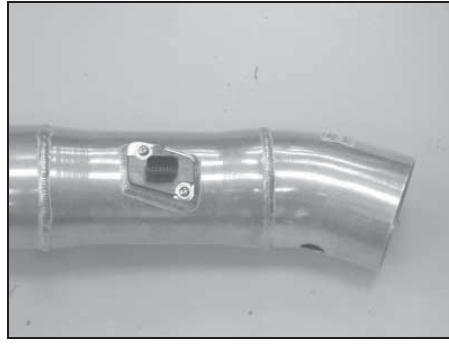

16. Install the mass air sensor into the K&N intake tube with the provided hardware as shown.



17. Install the grommet provided into the K&N intake tube as shown.

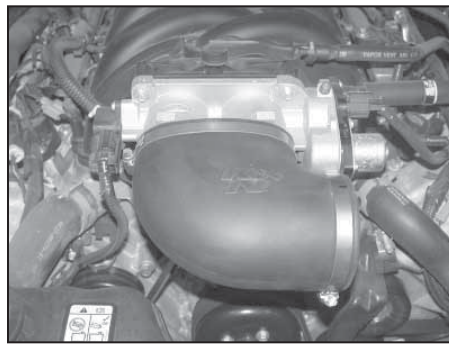

18. Install the silicone hose (084094) onto the throttle body with the provided hose clamp as shown.

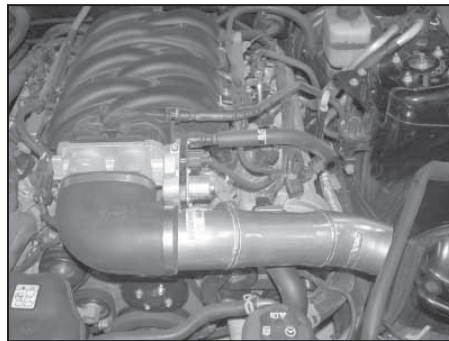

19. Install the K&N intake tube into the silicone hose at the throttle body and onto the mounting bracket installed in step #9, then secure with provided hose clamp and 6mm bolt.



20. Install the provided 90 deg hose mender into the provided crankcase vent hose as shown.

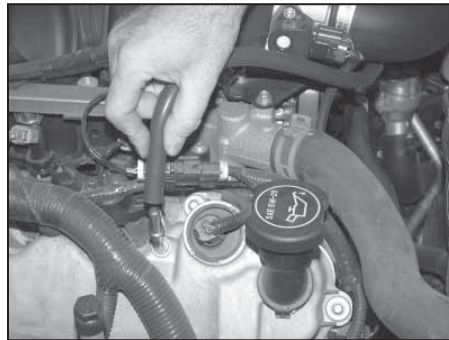

21. Install the crank case vent hose mender into the grommet installed in the K&N intake tube and then onto the valve cover as shown.

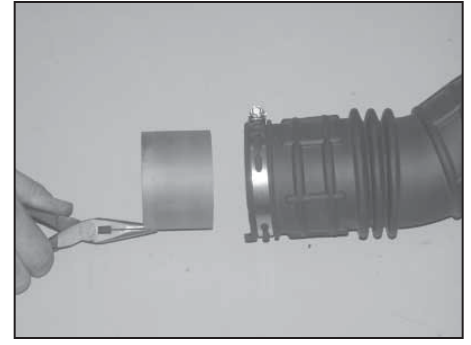

22. This step only applies to 2005 models equipped with an air box part number of 4R33-9C662-BJ or 4R33-9C662-CF, use a pair of needle nose pliers and remove the Hydrocarbon trap from the stock intake tube as shown.

**NOTE: The Hydrocarbon trap coating is very fragile; care should be taken during removal as not to damage it.**

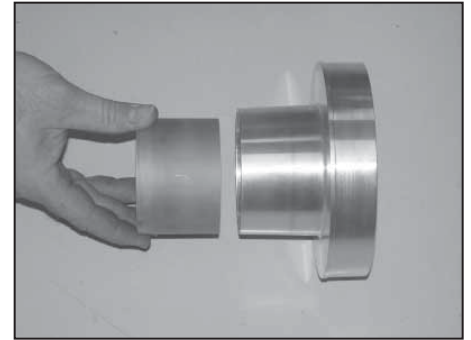

23. Place the Hydrocarbon trap into the filter adapter as shown.

**NOTE: On models equipped with a Hydrocarbon trap, it is required that it be reinstalled for legal installation of this intake kit. Failure to install the Hydrocarbon trap may result in poor engine performance.**



24. Install the silicone hose (08698) onto the filter adapter and secure with the provided hose clamp as shown.

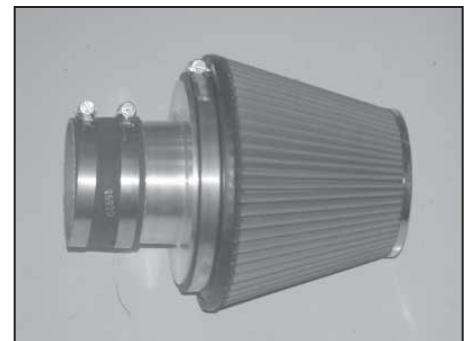

25. Install the air filter onto the filter adapter and secure with the provided hose clamp as shown.

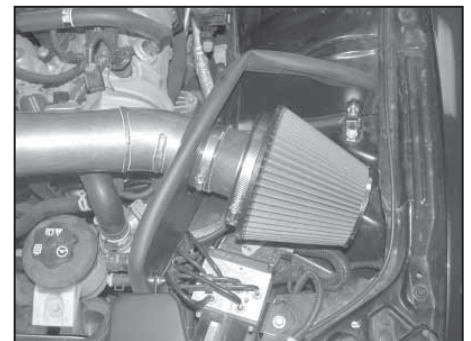

26. Install the air filter assembly onto the K&N intake tube as shown and secure with the provided hose clamp.

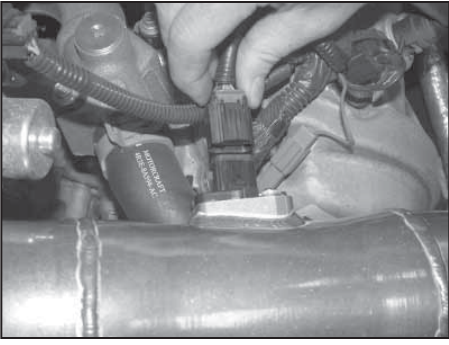

27. Reconnect the mass air sensor electrical connection as shown.

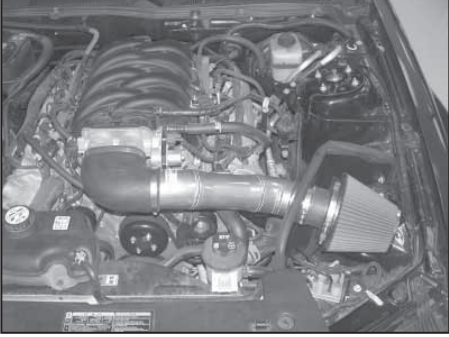

28. Reconnect the vehicle's negative battery cable. Double check to make sure everything is tight and properly positioned before starting the vehicle.

29. The C.A.R.B. exemption sticker, (attached), must be visible under the hood so that an emissions inspector can see it when the vehicle is required to be tested for emissions. California requires testing every two years, other states may vary.

30. It will be necessary for all K&N® high flow intake systems to be checked periodically for realignment, clearance and tightening of all connections. Failure to follow the above instructions or proper maintenance may void warranty.

#### ROAD TESTING:

1. Start the engine with the transmission in neutral or park, and the parking brake engaged. Listen for air leaks or odd noises. For air leaks secure hoses and connections. For odd noises, find cause and repair before proceeding. This kit will function identically to the factory system except for being louder and much more responsive.

2. Test drive the vehicle. Listen for odd noises or rattles and fix as necessary.

3. If road test is fine, you can now enjoy the added power and performance from your kit.

4. K&N Engineering, Inc., requires cleaning the intake system's air filter element every 100,000 miles. When used in dusty or off-road environments, our filters will require cleaning more often. We recommend that you visually inspect your filter once every 25,000 miles to determine if the screen is still visible. When the screen is no longer visible some place on the filter element, it is time to clean it. To clean and re-oil, purchase our filter Recharger® service kit, part number 99-5050 or 99-5000 and follow the easy instructions.

**STREET LEGAL IN MOST STATES**

**NOT LEGAL FOR USE IN CA & OTHER STATES  
ADOPTING CA EMISSIONS STANDARDS**

**See our catalog or [knfilters.com](http://knfilters.com) for CARB status on each part for a specific vehicle**

\* FREE K&N® decal To register your warranty, please see us online at [knfilters.com/register](http://knfilters.com/register). FREE K&N® decal \*