



TYPHOON INTAKE SYSTEMS

INSTALLATION INSTRUCTIONS

69-2543
DODGE
2008-10 Avenger
V6-3.5L

TOOLS NEEDED:

- 10mm socket
- 14mm socket
- 15mm socket
- 10mm wrench
- extension
- flat bladescrew driver
- pliers
- ratchet

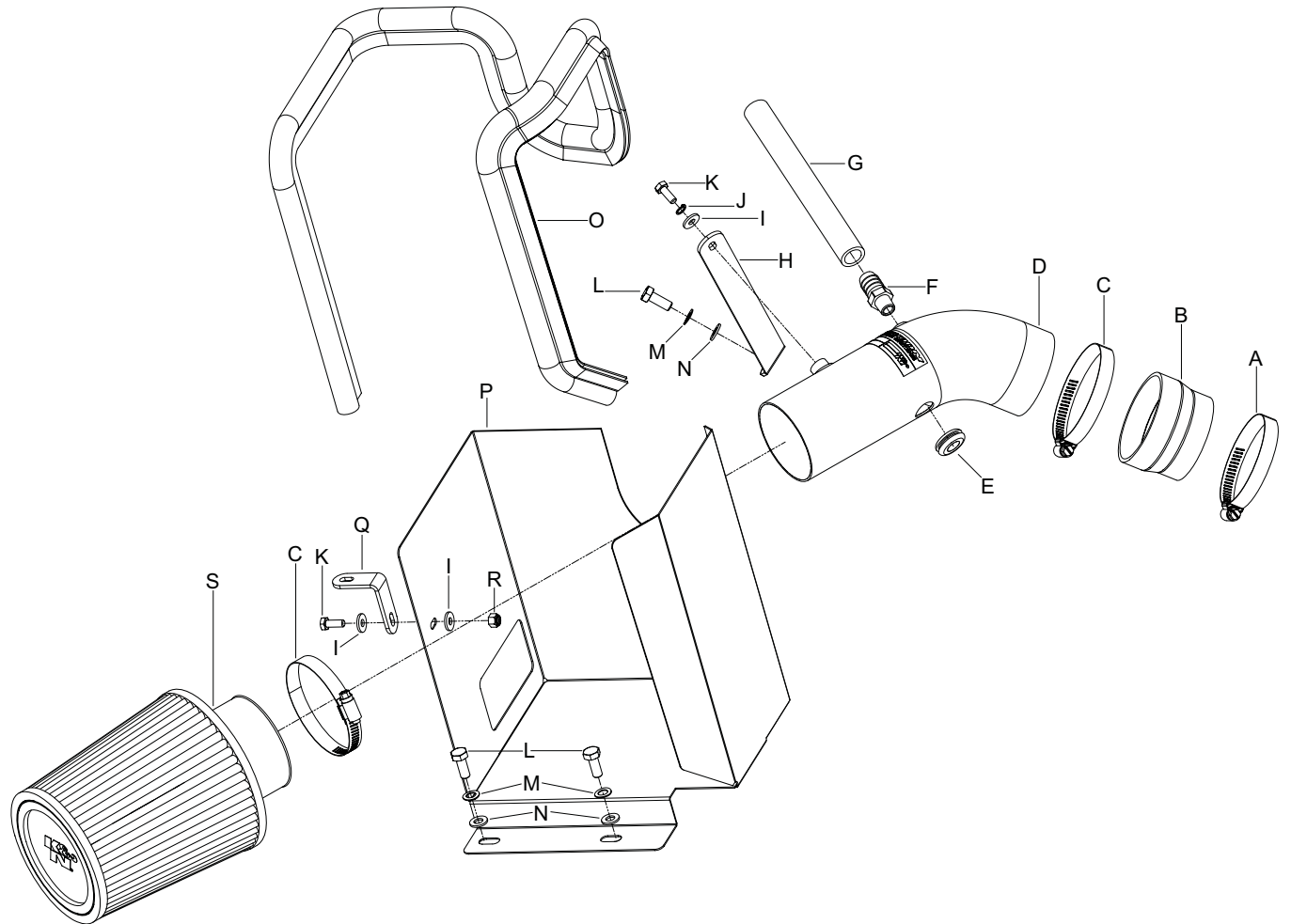

PARTS LIST:

Description	Qty.	Part #	Description	Qty.	Part #	Description	Qty.	Part #
A Hose Clamp #44 Stainless	1	08560	H Bracket; "L", Stl., FB/PC	1	070117	O Edge Trim (55")	1	102480
B Hose; 2-3/4" to 3" x 2"L, Silicone Blk.	1	084036	I Washer; 1/4"ID x 5/8"OD - SAE	3	08275	P Heat Shield	1	073103
C Hose Clamp #48	2	08601	J Washer; 1/4" Lock, ZN	1	08198	Q Bracket; "L"	1	26517
D Intake Tube	1	27426TTK	K Bolt; 6mm-1.00 x 16mm, SS	2	07812	R Nut; 6mm Nylock, Hex Head, SS	1	07512
E Grommet; 1-1/16OD, 1/2ID, 3/8 THK	1	080544	L Bolt; 8mm-1.25 x 20mm Hex Head, ZN	3	07787	S Air Filter	1	RU-4730
F Vent; Strt., 5/8 Barbed 1/4 NPT, Nylon	1	08911	M Washer; 8mm Spring (Wave)	3	08239			
G Hose; 5/8"ID x 7-1/2"L, Silicone Blk.	1	084008	N Washer; 8mm, Flat, SS	3	08272			

NOTE: FAILURE TO FOLLOW INSTALLATION INSTRUCTIONS AND NOT USING THE PROVIDED HARDWARE MAY DAMAGE THE INTAKE TUBE, THROTTLE BODY AND ENGINE.

TO START:

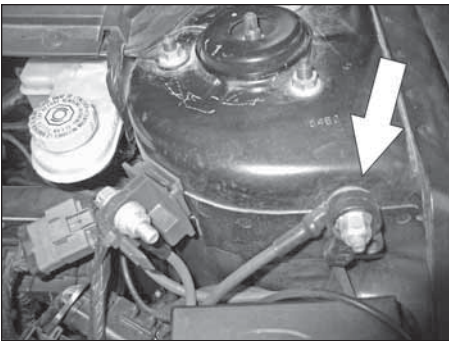

1. Turn off the ignition and disconnect the negative battery cable at the junction on the strut tower.

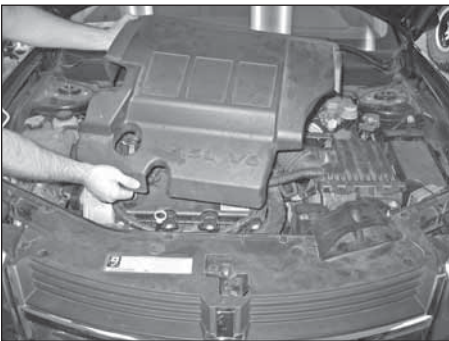

2. Lift up the engine cover and remove it from the engine.

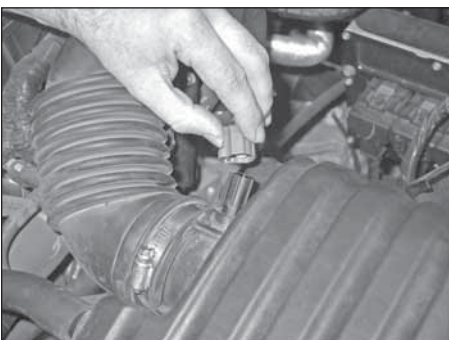

3. Disconnect the inlet air temperature sensor electrical connection.

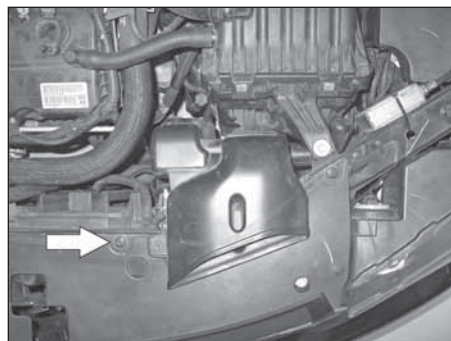

4. Remove the plastic retaining clip which secures the fresh air intake scoop to the core support.

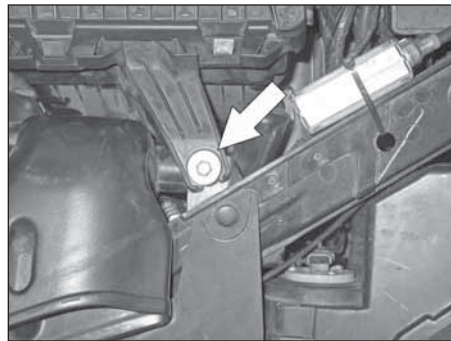

5. Remove the air box retaining bolt shown. This bolt will be reused in a later step.



6. Disconnect the crank case vent hose from valve cover port as shown.



7. Loosen the intake tube hose clamp and disconnect the intake tube from the throttle body. Then lift up and remove the complete stock intake assembly. **NOTE: On some models it may be necessary to remove the battery cable mounting bracket from the air box.**

NOTE: K&N Engineering, Inc., recommends that customers do not discard factory air intake.

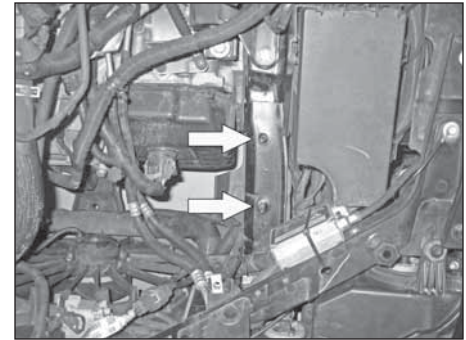

8. Remove the two air box mounting studs from the frame rail.

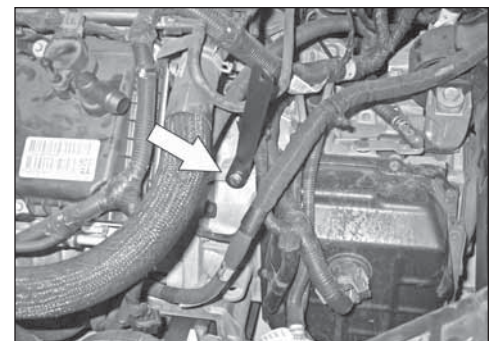

9. Install the tube mounting bracket (070117) onto the transmission case using the provided hardware.



10. Install the provided edge trim onto the heat shield as shown.

NOTE: Some trimming of the edge trim will be necessary.



11. Install the heat shield mounting bracket (26517) onto the heat shield as shown using the provided hardware.



12. Disconnect the fresh air scoop from the air box as shown.



13. Install the fresh air scoop into the heat shield as shown.

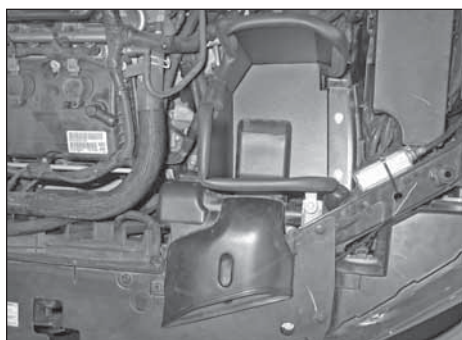

14. Install the heat shield assembly onto the frame rail. Secure the heat shield assembly to the factory air box mounting locations with the factory bolt and hardware provided. Secure the fresh air intake scoop to the core support using the factory mounting pin.



15. Install the provided grommet into the K&N® intake tube as shown.



16. Install the provided NPT fitting into the K&N® intake tube as shown.



17. Remove the inlet air temperature sensor from the stock intake tube.

NOTE: Take care removing the temp sensor as it is very fragile.

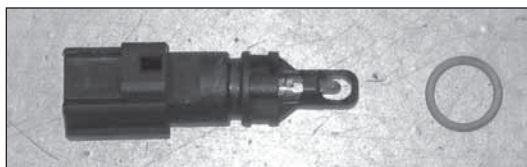

18. Remove the o-ring from the temperature sensor as shown.

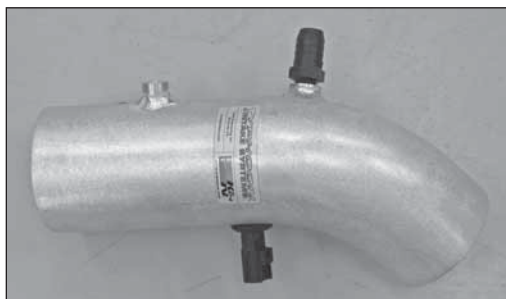

19. Install the inlet air temperature sensor into the grommet installed into the K&N® intake tube.
NOTE: Take care installing the temp sensor as it is very fragile.

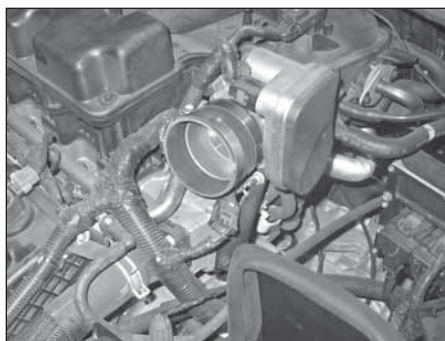

20. Install the provided silicone hose (084036) onto the throttle body and secure with the provided hose clamp.

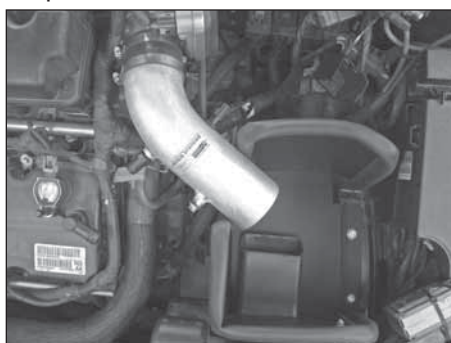

21. Install the K&N® intake tube into the silicone hose at the throttle body, aligning the tube with the mounting bracket. Secure with the provided hose clamp and hardware provided.

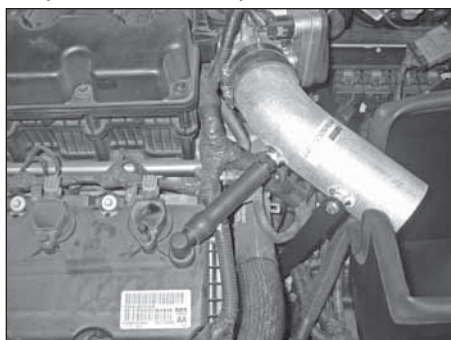

22. Install the provided crank case vent hose onto the fitting on the valve cover. Then connect the open end to the NPT fitting installed into the K&N® intake tube.

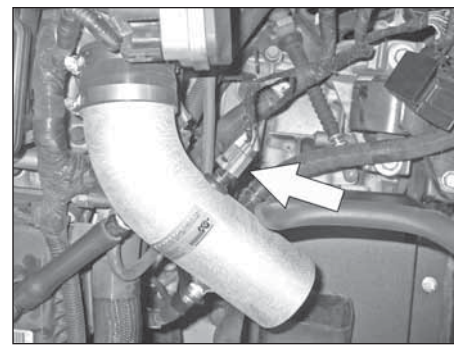

23. Reconnect the inlet air temperature sensor electrical connection.

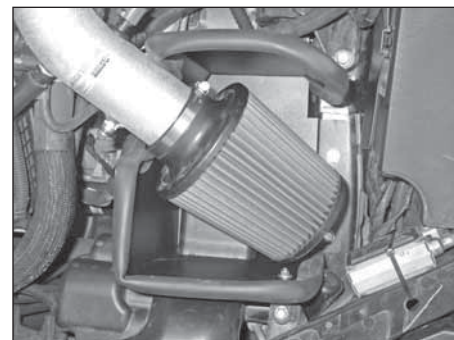

24. Install the K&N® air filter onto the intake tube and secure with the provided hose clamp.

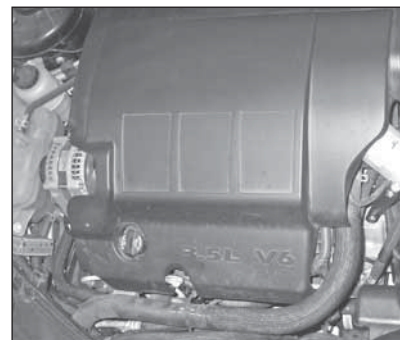

25. Reinstall the engine cover.

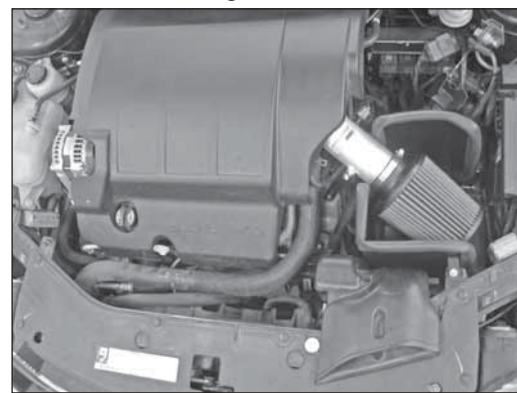

26. Reconnect the vehicle's negative battery cable. Double check to make sure everything is tight and properly positioned before starting the vehicle.

27. It will be necessary for all K&N® high flow intake systems to be checked periodically for realignment, clearance and tightening of all connections. Failure to follow the above instructions or proper maintenance may void warranty.

ROAD TESTING:

1. Start the engine with the transmission in neutral or park, and the parking brake engaged. Listen for air leaks or odd noises. For air leaks secure hoses and connections. For odd noises, find cause and repair before proceeding. This kit will function identically to the factory system except for being louder and much more responsive.

2. Test drive the vehicle. Listen for odd noises or rattles and fix as necessary.

3. If road test is fine, you can now enjoy the added power and performance from your kit.

4. K&N Engineering, Inc., suggests checking the air filter element periodically for excessive dirt build-up. When the element becomes covered in dirt (or once a year), service it according to the instructions on the Recharger® service kit, part number 99-5050 or 99-5000.