



INSTALLATION INSTRUCTIONS

57-3061 CHEVROLET 2006-08 Trailblazer SS V8-6.0L

NOTE: This kit was not designed to fit vehicles with a body lift.

TOOLS NEEDED:

- 7mm Socket
- 10mm Socket
- 15mm Socket
- 10mm Wrench
- 15mm Wrench
- 5/8" Wrench
- Extension
- Flat Blade Screwdriver
- Phillips Screwdriver
- Ratchet
- Side Cutters
- Tape Measure

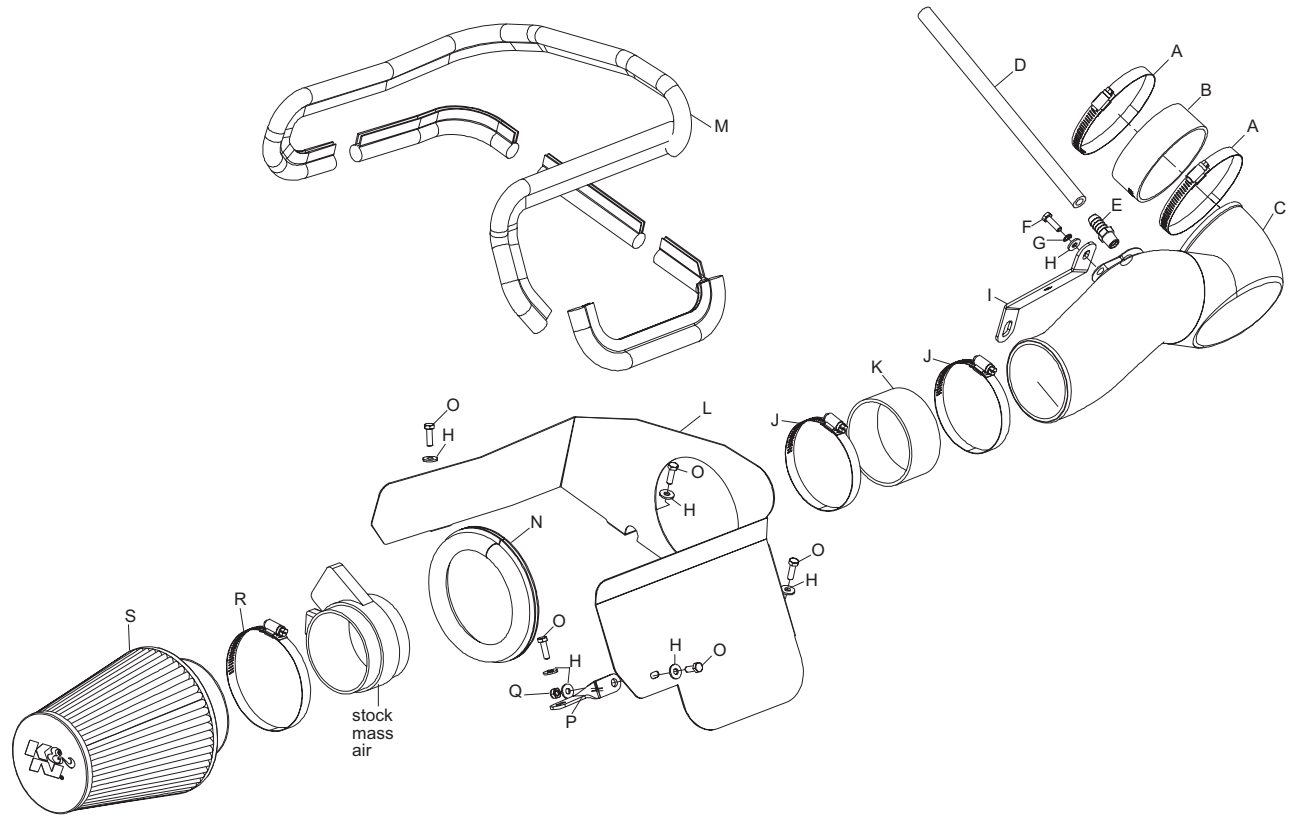

PARTS LIST:

Description	Qty.	Part #	Description	Qty.	Part #	Description	Qty.	Part #
A Hose Clamp #64	2	08650	H Washer; 1/4"ID X 5/8"OD - SAE	7	08275	O Bolt; M6-1.00 X 20MM Hexhead	5	07865
B Hose; 4"ID X 1.5"L, Silicone	1	08755	I Bracket	1	26630	P Bracket	1	26606
C Intake Tube	1	087199-1	J Hose Clamp #56	2	08620	Q Nut; 6MM Nylock, Hexhead	1	07553
D Hose; 3/8"ID X 12"L, Silicone	1	08412	K Hose; 3.63"ID X 1.75"L, Silicone	1	08615	R Hose Clamp #64	1	08648
E Vent; Strt. 1/2" Hose, 1/4"NPT,	1	080022	L Heat Shield	1	07676	S Air Filter	1	RF-1032
F Bolt; M6-1.00 X 16MM Hexhead.	1	07703	M Edge Trim 83"L	1	102503			
G Washer; 1/4" Lock, ZN	1	08198	N Edge Trim 17"L	1	102469			

NOTE: FAILURE TO FOLLOW INSTALLATION INSTRUCTIONS AND NOT USING THE PROVIDED HARDWARE MAY DAMAGE THE INTAKE TUBE, THROTTLE BODY AND ENGINE.

TO START:

1. Turn off the ignition and disconnect the negative battery cable.

NOTE: Disconnecting the negative battery cable erases pre-programmed electronic memories. Write down all memory settings before disconnecting the negative battery cable. Some radios will require an anti-theft code to be entered after the battery is reconnected. The anti-theft code is typically supplied with your owner's manual. In the event your vehicles' anti-theft code cannot be recovered, contact an authorized dealership to obtain your vehicles anti-theft code.



2. Remove the wing nut, which retains the engine cover and then remove the engine cover.

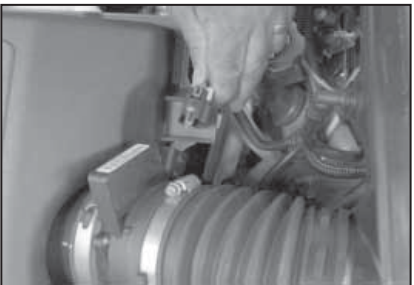

3. Depress the locking tab on the mass air sensor electrical connection and then separate the connector from the mass air sensor.

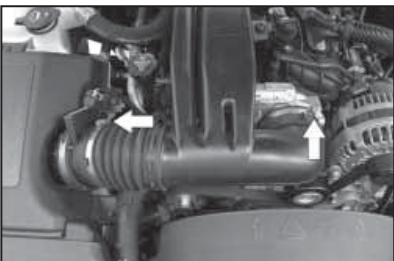

4. Loosen the two hose clamps, which secure the intake tube to the mass air sensor and throttle body.

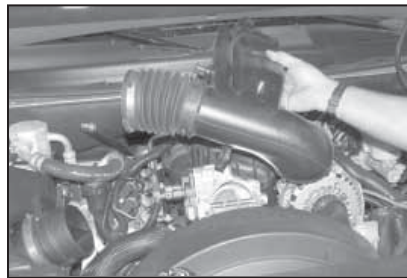

5. Disconnect the crankcase vent hose from the valve cover and then remove the stock intake tube as shown.

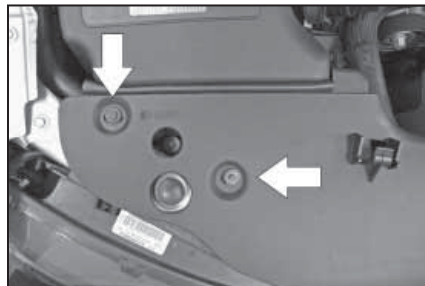

6. Remove the core support cover bolt and retaining clip shown.

NOTE: The bolt and retaining clip will be used.

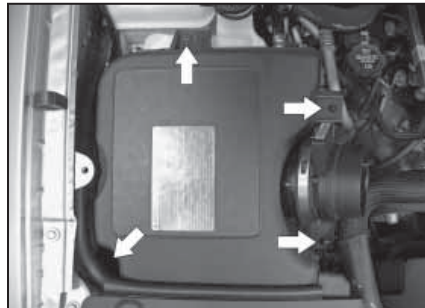

7. Loosen the four airbox lid retaining bolts shown.

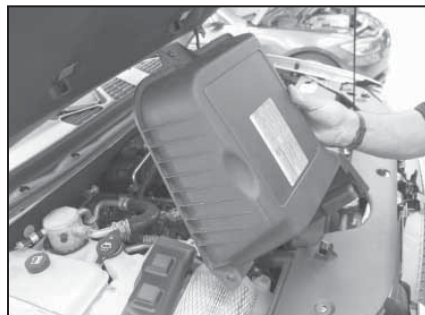

8. Lift up on the core support cover for clearance and then remove the airbox lid as shown.

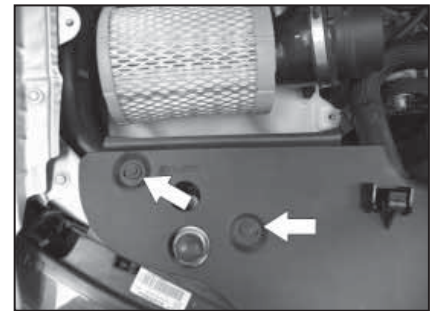

9. Reinstall the retaining clip and bolt removed in step #6 to secure the core support cover.

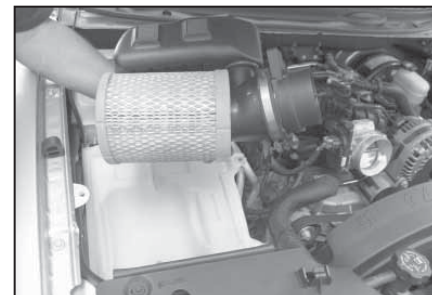

10. Remove the filter and mass air sensor assembly from the vehicle as shown.

NOTE: K&N Engineering, Inc., recommends that you do not discard your factory air intake.

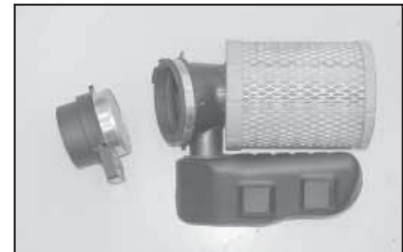

11. Loosen the hose clamp, which secures the mass air sensor to the filter assembly, and then remove the mass air sensor as shown.



12. Install the 17" piece of edge trim onto the top of the front wall of the edge trim as shown.

NOTE: Some trimming of the edge trim will be necessary.

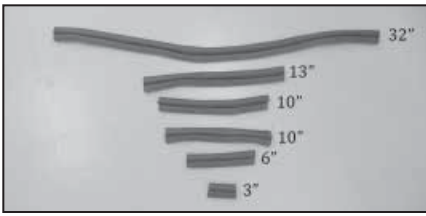

13. Cut the supplied long edge trim into lengths of 32", 13", 6", 3" and 2 pieces at 10".

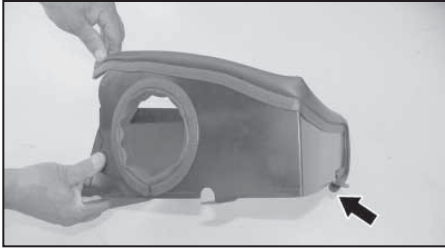

14. Starting at the rear-mounting tab, install the 32" long edge trim onto the heat shield as shown.



15. Install the 13" long edge trim onto the top of the front wall of the heat shield as shown.

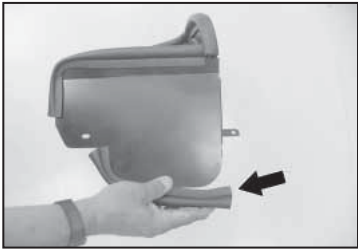

16. Install one of the 10" pieces onto the bottom of the front wall as shown.

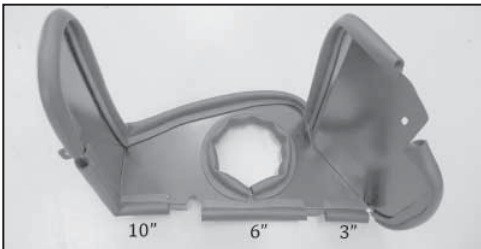

17. Install the remaining 10", 6" and 3" edge trim to the bottom of the heat shield as shown.

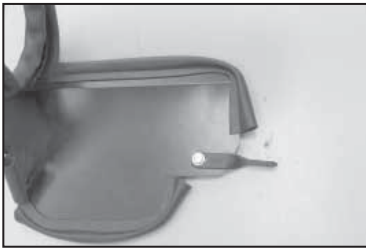

18. Install the mounting bracket onto the heat shield with the provided hardware as shown.
NOTE: The slotted end of the bracket will fasten to the heat shield.

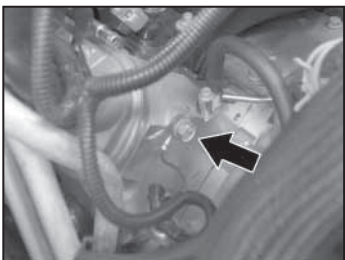

19. Remove the bolt, which secures the ground strap to the cylinder head shown.
NOTE: This bolt will be reused.

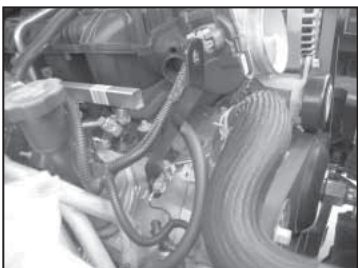

20. Using the bolt removed in step #19, secure the tube mounting bracket and ground strap to the cylinder head in the same location the bolt was removed from.

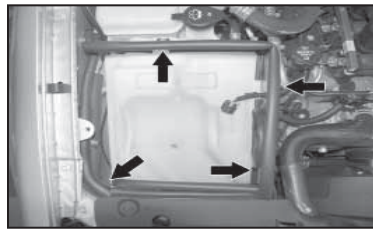

21. Install the heat shield onto the washer reservoir and secure the heat shield and mounting bracket with the provided hardware.

NOTE: Be sure to place the mass air sensor wiring harness through the notch in the heat shield before tightening.

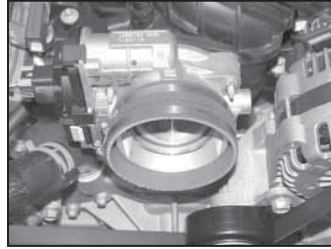

22. Install the silicone hose (08755) onto the throttle body and secure with the provided hose clamp as shown.

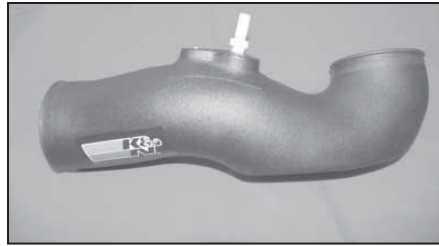

23. Install the provided vent fitting into the intake tube as shown.



24. Install the intake tube into the silicone hose at the throttle body and align with the mounting bracket installed in step #20. Secure the tube with the provided hose clamp and hardware. Do not completely tighten at this time.

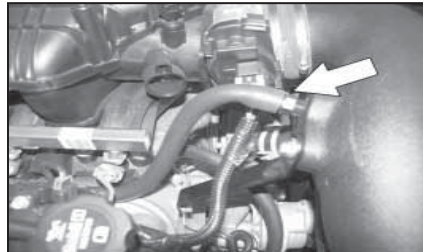

25. Connect the supplied crankcase vent hose onto the valve cover and then connect to the intake tube as shown.



26. Install the silicone hose (08615) onto the mass air sensor as shown and secure with the provided hose clamp.

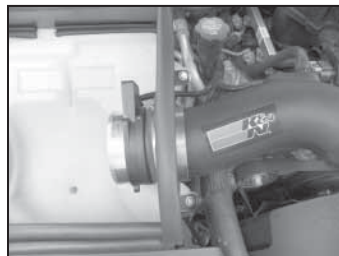

27. Install the mass air sensor assembly onto the intake tube and secure with the hose clamp provided.

NOTE: Rotate the mass air sensor so the electrical connection is positioned down towards the electrical connection.



28. Reconnect the mass air sensor electrical connection.

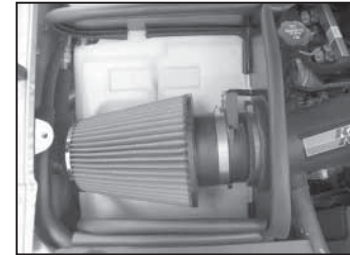

29. Install the K&N[®] Air Filter onto the mass air sensor and secure with the provided hose clamp as shown.



30. Reinstall the engine cover and secure with the factory wing nut.

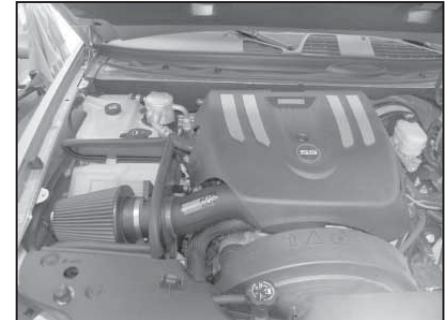

31. Reconnect the vehicle's negative battery cable. Double check to make sure everything is tight and properly positioned before starting the vehicle.

32. The C.A.R.B. exemption sticker, (attached), must be visible under the hood, so the emissions inspector can see it when the vehicle is required to be tested for emissions. California requires testing every two years, other states may vary.

33. It will be necessary for all FIPK's to be checked periodically for realignment, clearance and tightening of all connections. Failure to follow the above instructions or proper maintenance may void warranty.

ROAD TESTING:

1. Start the engine with the transmission in neutral or park, and the parking brake engaged. Listen for air leaks or odd noises. For air leaks secure hoses and connections. For odd noises, find cause and repair before proceeding. This kit will function identically to the factory system except for being louder and much more responsive.

2. Test drive the vehicle. Listen for odd noises or rattles and fix as necessary.

3. If road test is fine, you can now enjoy the added power and performance from your kit.

4. K&N Engineering, Inc., suggests checking the air filter element periodically for excessive dirt build-up. When the element becomes covered in dirt (or once a year), service it according to the instructions on the Recharger[®] service kit, part number 99-5050 or 99-5000.

50-STATE STREET LEGAL
K&N CARB EXEMPT K&N

FREE K&N DECAL To register your warranty, please see us online at knfilters.com/register. FREE K&N DECAL

• 1455 CITRUS St., P.O. BOX 1329, RIVERSIDE, CA., U.S.A. 92502 • TECH SERVICE 800-858-3333 • FAX 909-826-4001
• e-mail: tech@knfilters.com • WWW: <http://www.knfilters.com>

19517D
08/15/11