



## INSTALLATION INSTRUCTIONS

**57-3031-1**

**CHEVROLET / GMC**

2007 Silverado / Sierra 2500HD Classic, 3500 Classic

V8-6.0L

2007 Sierra 2500HD Classic, 3500 Classic

V8-8.1L

2001-06 Silverado / Sierra 2500HD, 3500

V8-8.1L

2001-06 Silverado / Sierra 2500HD, 3500

V8-6.0L

**TOOLS NEEDED:**

Flat Blade Screwdriver

4mm Allen Wrench

1/2" Wrench

**PARTS LIST:**

	Description	Qty.	Part #
A	Hose clamp # 64 midi	2	08650
B	Silicone hose	1	08755
C	Intake tube	1	087019
D	Hose clamp # 60	2	08624
E	Hump hose	1	08176
F	Bolt, 5mm allen	3	08320
G	Gasket	2	09033
H	Heat shield	1	07451
I	Edge trim 50"L	1	102481
J	Mass air adapter	1	08783
K	Hose clamp # 104	1	08697
L	Air Filter	1	RF-1041

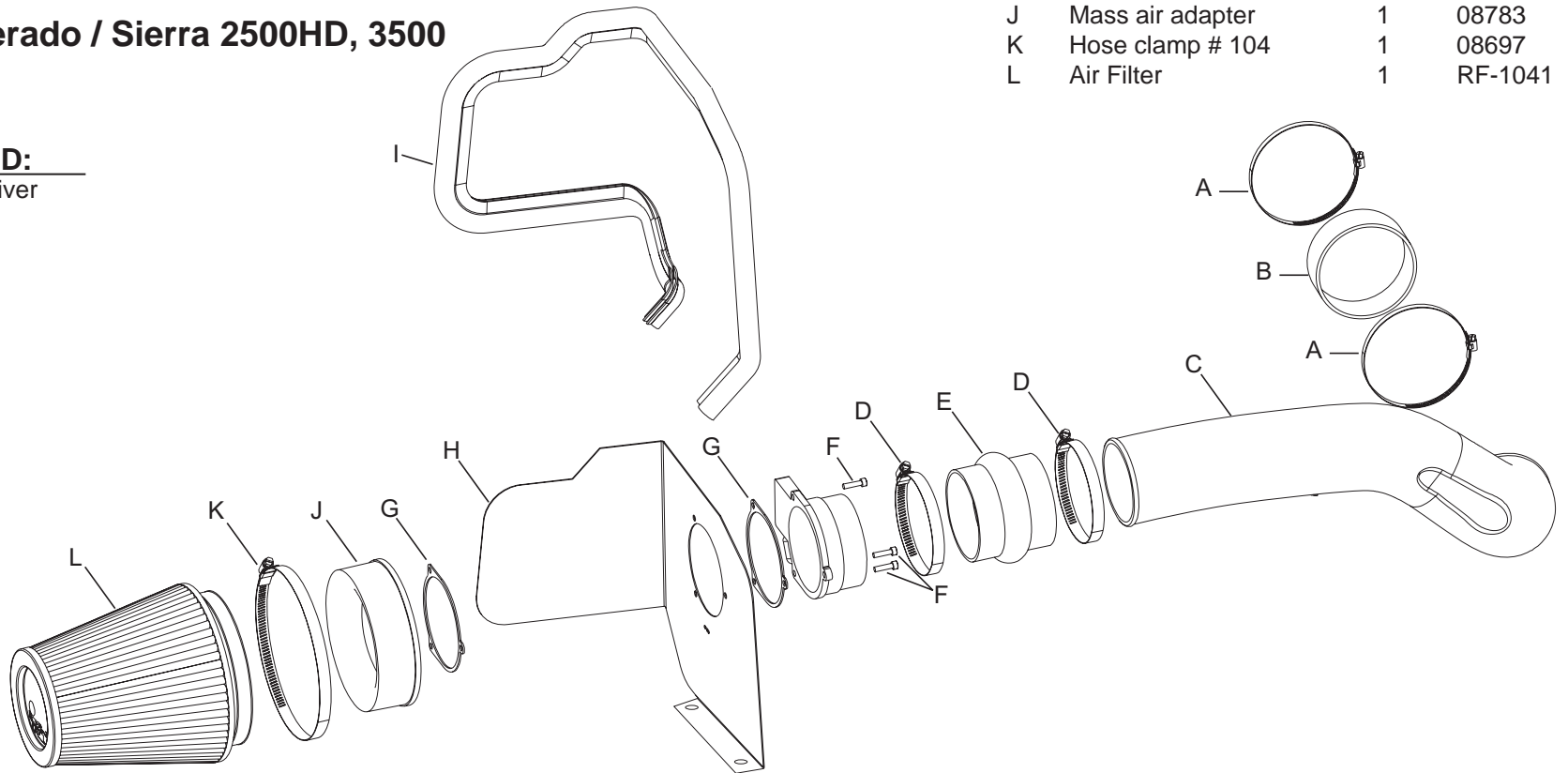

**NOTE: FAILURE TO FOLLOW INSTALLATION INSTRUCTIONS AND NOT USING THE PROVIDED HARDWARE MAY DAMAGE THE INTAKE TUBE, THROTTLE BODY AND ENGINE.**

**TO START:**

1. Turn off the ignition and disconnect the negative battery cable.

**NOTE: Disconnecting the negative battery cable erases pre-programmed electronic memories. Write down all memory settings before disconnecting the negative battery cable. Some radios will require an anti-theft code to be entered after the battery is reconnected. The anti-theft code is typically supplied with your owner's manual. In the event your vehicles' anti-theft code cannot be recovered, contact an authorized dealership to obtain your vehicles anti-theft code.**

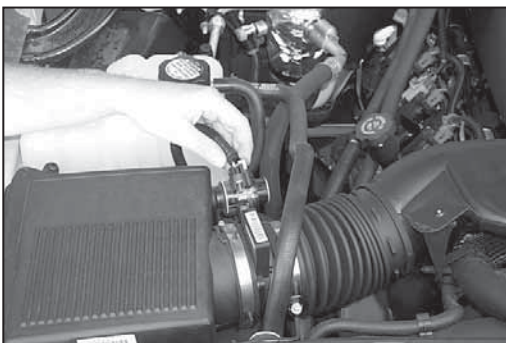

2. Disconnect the mass air sensor electrical connection.

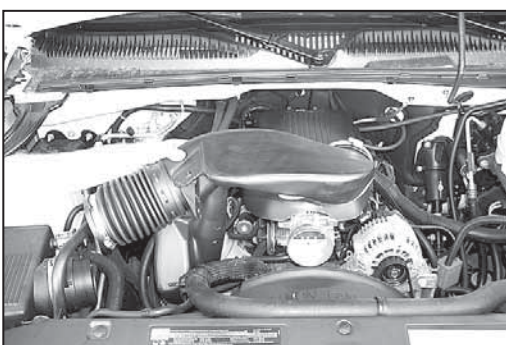

3. Loosen the hose clamps at the throttle body and at the mass air sensor, then remove the factory intake tube as shown.

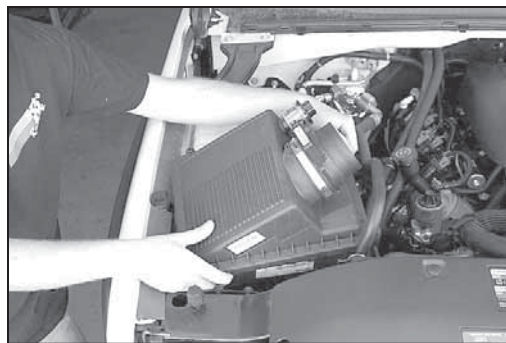

4. Pull firmly upwards to release the air cleaner assembly from the mounting tray grommets, then remove the assembly.

**NOTE: K&N Engineering, Inc., recommends that customers do not discard factory air intake.**

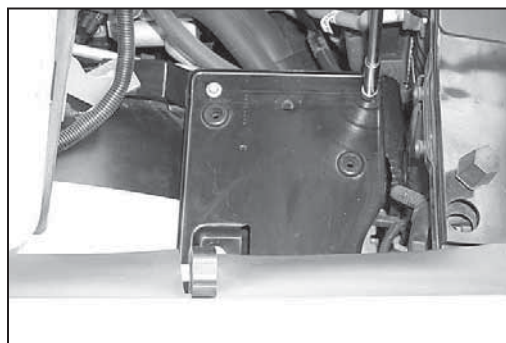

5. Loosen and remove the two air cleaner mounting tray bolts as shown.

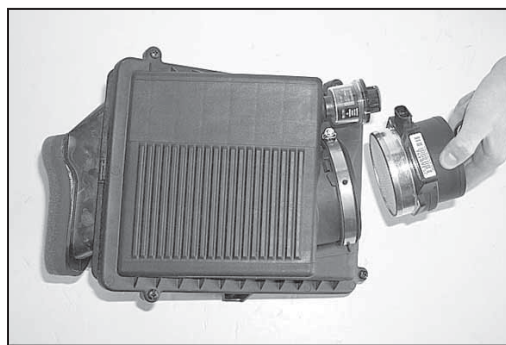

6. Loosen the hose clamp and remove the mass air sensor from the air cleaner.

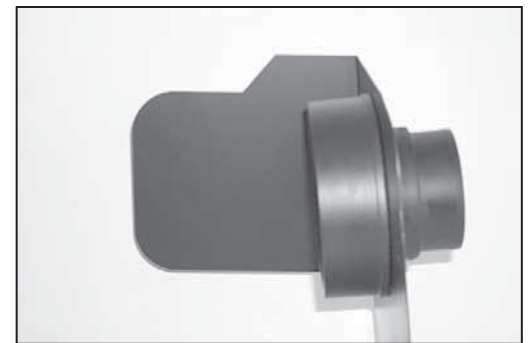

7. Assemble the mass air adapter, heat shield, gaskets and the mass air sensor as shown above.

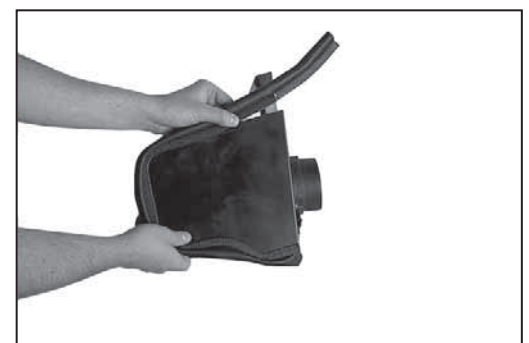

8. Apply the trim seal to the heat shield assembly as shown.

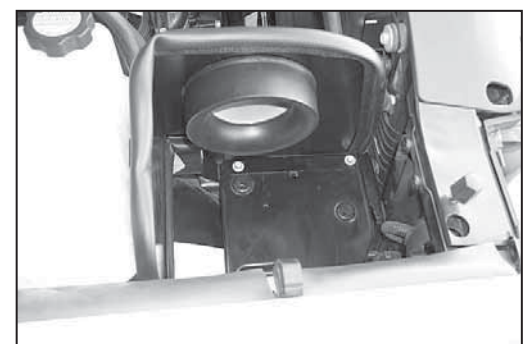

9. Install and mount the heat shield assembly to the air cleaner mounting tray using the bolts removed in step 5.

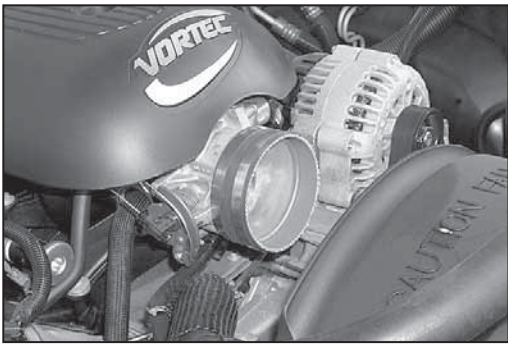

10. Install the silicone hose and hose clamps onto the throttle body as shown.



11. Install the silicone hump hose and hose clamps onto the K&N® intake tube as shown.

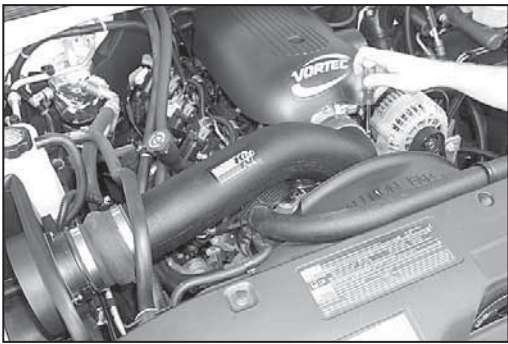

12. Install the K&N® intake tube onto the mass air sensor, then secure the other end onto the throttle body as shown.

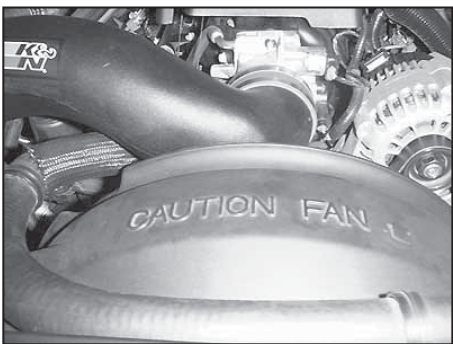

13. Due to production tolerances it may be necessary to mark the fan shroud as indicated, remove the intake tube and trim the fan shroud.

**NOTE: Be sure to cover the throttle body and alternator during this process.**

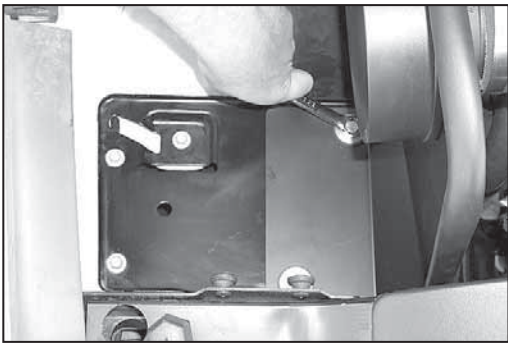

14. Adjust the heat shield and intake tube for best fit, then tighten the two hex bolts as shown.

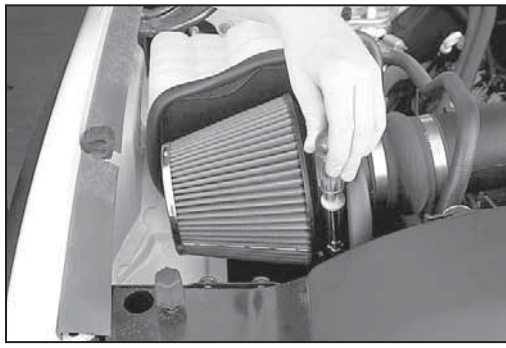

15. Install the K&N® air filter onto the heat shield assembly as shown.

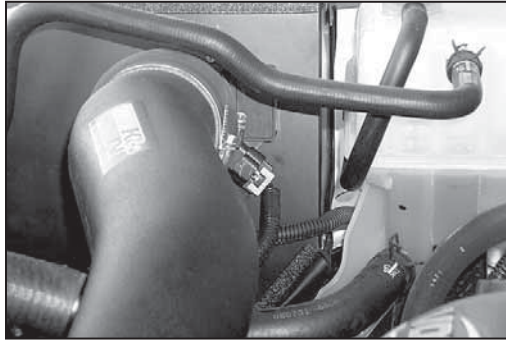

16. Reconnect the mass air sensor electrical connection as shown.

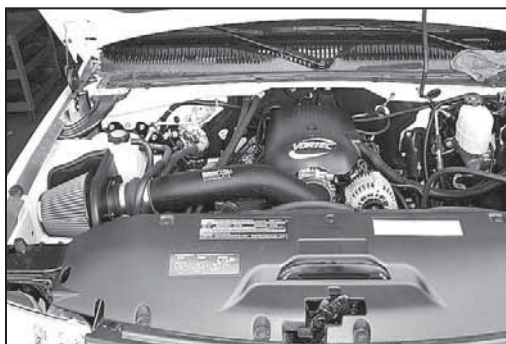

17. Reconnect the vehicle's negative battery cable. Double check to make sure everything is tight and properly positioned before starting the vehicle.

18. The C.A.R.B. exemption sticker, (attached), must be visible under the hood so that an emissions inspector can see it when the vehicle is required to be tested for emissions. California requires testing every two years, other states may vary.

19. It will be necessary for all K&N® high flow intake systems to be checked periodically for realignment, clearance and tightening of all connections. Failure to follow the above instructions or proper maintenance may void warranty.

#### ROAD TESTING:

1. Start the engine with the transmission in neutral or park, and the parking brake engaged. Listen for air leaks or odd noises. For air leaks secure hoses and connections. For odd noises, find cause and repair before proceeding. This kit will function identically to the factory system except for being louder and much more responsive.

2. Test drive the vehicle. Listen for odd noises or rattles and fix as necessary.

3. If road test is fine, you can now enjoy the added power and performance from your kit.

4. K&N Engineering, Inc., suggests checking the air filter element periodically for excessive dirt build-up. When the element becomes covered in dirt (or once a year), service it according to the instructions on the Recharger® service kit, part number 99-5050 or 99-5000.

**50-STATE STREET LEGAL**  
**K&N CARB EXEMPT**  
**K&N**

\* FREE K&N® decal To register your warranty, please see us online at [knfilters.com/register](http://knfilters.com/register). FREE K&N® decal \*