

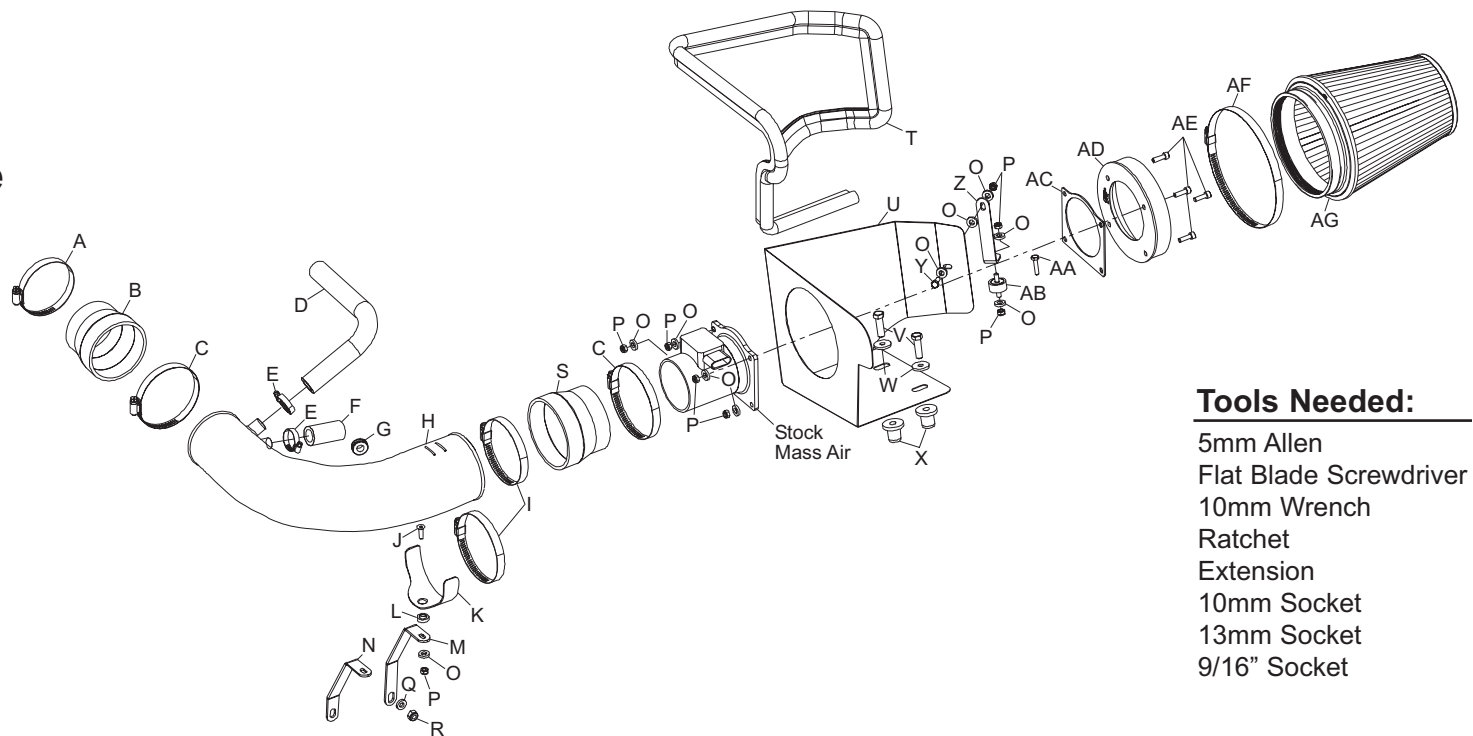

INSTALLATION INSTRUCTIONS

57-2541

Ford / Lincoln
1997-04 F150 Heritage
V8- 4.6L, 5.4L
1997-03 F150
V8- 4.6L, 5.4L
1997-02 Expedition
V8- 4.6L, 5.4L
1998-99 Navigator
V8- 5.4L SOHC



- Tools Needed:**
- 5mm Allen
 - Flat Blade Screwdriver
 - 10mm Wrench
 - Ratchet
 - Extension
 - 10mm Socket
 - 13mm Socket
 - 9/16" Socket

NOTE: This kit was not designed to fit vehicles with a body lift.

Parts List:

Desc.	Qty.	Part #	Desc.	Qty.	Part #	Desc.	Qty.	Part #
A Hose Clamp #48	1	08601	J Bolt; 6mm-1.00 x 20mm f/h/a	1	08376	S Hose; 4" id to 3.5" id, tprd	1	08050
B Hose; 3.5" id to 3" id, tprd Silicone	1	08724	K Saddle Bracket	1	078855	T Edge Trim 55"	1	102480
C Hose Clamp #56	2	08620	L Washer, Conical, Nylon	1	08180	U Heat Shield	1	07483
D Hose; 3/4" id, 90 Deg. Rubber	1	08704	M Bracket; long "L"	1	26657	V Bolt; 3/8" x 1.25	2	07779
E Hose Clamp #12 mini	2	08420	N Bracket; short "L"	1	083115	W Fender Washer	2	08126
F Hose; 3/4" id, 2-1/4" l, Rubber	1	08709	O Washer; 1/4" id x 5/8" od, Flat	10	08275	X Insert; 3/8"	2	08163
G Grommet, 7/16" id	1	08092	P Nut, 6mm Nylock	8	07553	Y Bolt 6mm x 16mm	1	07703
H Intake Tube (M)	1	08864	Q Washer; 5/16" ID x 5/8" od, Flat	1	08276	Z Bracket, "L"	1	070952
I Hose Clamp #64	2	08648	R Nut, 8mm Nylock	1	07542	AA Bolt 6mm x 25mm	1	07704
						AB Rubber MNTD Stud m6-1.00	1	07027
						AC Gasket; 1/16" Neoprene	1	09984
						AD Adapter, #210	1	08854
						AE Bolt, 6mm-1.00x20mm Allen	4	07852
						AF Hose Clamp #104	1	08697
						AG Air Filter	1	RC-5046

NOTE: FAILURE TO FOLLOW INSTALLATION INSTRUCTIONS AND NOT USING THE PROVIDED HARDWARE MAY DAMAGE THE INTAKE TUBE, THROTTLE BODY AND ENGINE.

TO START:

1. Turn the ignition OFF and disconnect the vehicle's negative battery cable.

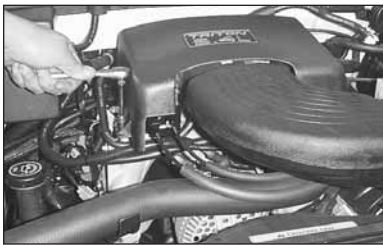

2. Loosen and remove the three bolts that retain the throttle body cover, then remove the cover.



3. Disconnect the air temperature sensor electrical connection.



4a. On models with 4.6L engines, detach the air bypass valve and crankcase vent hose from the stock intake tube.



4b. On models with 5.4L, detach the idle air control and crankcase vent hose from the stock intake tube.



5. Loosen the hose clamp on the stock intake tube at the throttle body.



6. Detach the stock intake tube from the throttle body and lift up on the air cleaner assembly to release it from its retaining grommets.



7. Disconnect the secondary mass air sensor electrical connection.



8. Remove the entire stock air intake assembly from the vehicle.
NOTE: K&N recommends that customers do not discard factory air intake.



9. Open the air cleaner assembly and isolate the mass air sensor assembly.



10. Slide the rubber grommet back and disconnect the primary mass air sensor electrical connection, using a flat blade screwdriver.



11. Using a flat blade screwdriver, push in and release the four clips that retain the mass air sensor retaining plate.



12. Using a pair of small vise grips or pliers, hold the stud while using a 10mm wrench to loosen the nuts, then remove the mass air sensor from the retaining plate.



13. Remove the two air box mounting grommets from vehicle as shown.



14. Install edge trim onto heat shield as shown. Trim if needed.



15. Remove the 6mm bolt that retains the cruise control onto vehicle.



15a. On vehicles without cruise control, install the rubber mounted stud onto vehicle as shown.



16. Install the provided "L" bracket (070952) onto heat shield as shown.
Note: Install a washer between heat shield and bracket.



17. Install the two nut inserts onto the air box mounting tray as shown.



18. On vehicles with cruise control install heat shield as shown with the provided hardware.



18a. On vehicles that did not come equipped with cruise control, install heat shield onto the vehicle, then secure with the provided hardware.



19. Remove the air temp. sensor from stock air intake tube as shown.



20. Using the grommet provided, install the air temperature sensor into the K&N intake tube.

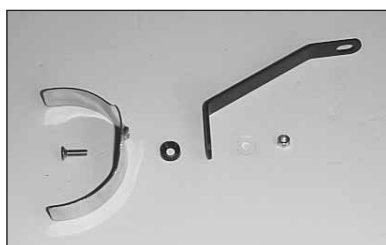

21. Assemble the saddle to the appropriate bracket using the hardware provided as shown.
NOTE: For vehicles equipped with the 4.6L engine, use the long "L" bracket (26657) and for vehicles equipped with the 5.4L engine, use the short "L" bracket (083115).



22. Install the saddle bracket assembly onto the protruding stud as shown, secure into place using the hardware provided.



23. Using the hose clamp provided, attach the silicone hose (08724) to the throttle body.



24. Install the K&N intake tube onto the throttle body, and tighten the hose clamp.



25. On models with 5.4L engines, install the idle air control and crankcase vent hose onto the appropriate fittings on the K&N intake tube, secure with the hose clamps provided.

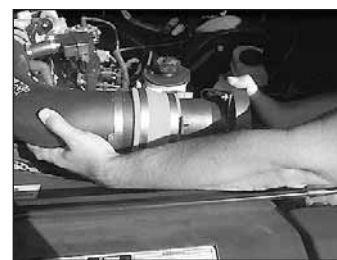

25a. On models with 4.6L engines, attach the crankcase vent and the 90 deg. hose provided onto the appropriate fittings on the K&N intake tube and secure with the hose clamps provided.

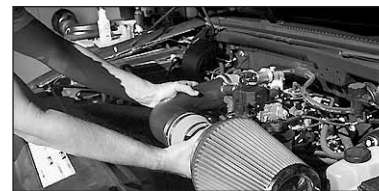

26. On models with 4.6L engines, in some insulated instances where a whistling noise may exist. Cut the flange of the air bypass valve just past the last barb. Reinstall the air bypass valve, attaching it to the appropriate fitting on the intake tube using the 3/4" id hose and hose clamps provided.



27. Attach the mass air adapter to the mass air sensor using the gasket and provided hardware.



28. Install silicone hose (#08050) onto the mass air sensor with the provided hardware as shown.



29. Attach the mass air assembly to the intake tube. Secure the mass air assembly and saddle bracket to the intake tube using the hose clamps provided.



30. Reconnect the primary and secondary mass air electrical connections.



31. Reconnect the air temp. sensor electrical connection.



32. Install the filter charger element onto the mass air adapter and secure it with the hose clamp provided.



33. Reinstall the engine cover removed in step #2.



34. Reconnect the vehicle's negative battery cable. Double check to make sure everything is tight and properly positioned before starting the vehicle.

35. The C.A.R.B. exemption sticker, (attached), must be visible under the hood, so that an emissions inspector can see it when the vehicle is required to be tested for emissions. California requires testing every two years, other states may vary.

36. It will be necessary for all FIPK's to be checked periodically for realignment, clearance and tightening of all connections. Failure to follow the above instructions or proper maintenance may void warranty.

ROAD TESTING:

1. Start the engine with the transmission in neutral or park, and the parking brake engaged. Listen for air leaks or odd noises. For air leaks secure hoses and connections. For odd noises, find cause and repair before proceeding. This kit will function identically to the factory system except for being louder and much more responsive.
2. Test drive the vehicle. Listen for odd noises or rattles and fix as necessary.
3. If road test is fine, you can now enjoy the added power and performance from your kit.
4. K&N suggests checking the air filter element periodically for excessive dirt build-up. When the element becomes covered in dirt (or once a year), service it according to the instructions on the Recharger service kit, part number 99-5050 or 99-5000.